

SUN SYNK

RACK-MOUNTED HYBRID PARITY (SUPER) INVERTER

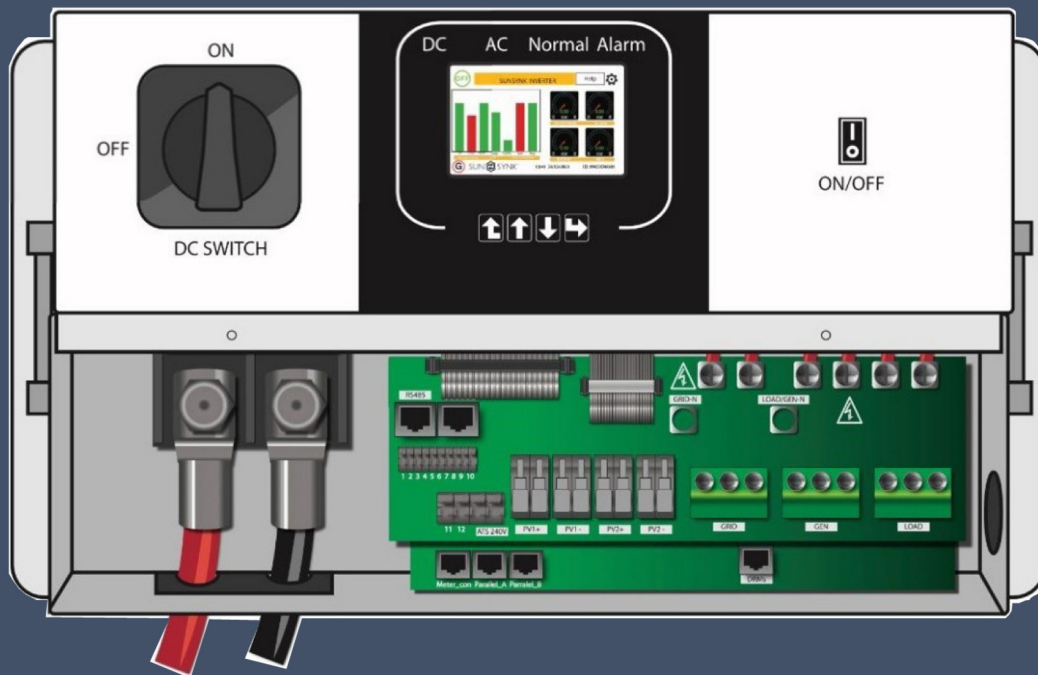

INSTALLER MANUAL

SUNSYNK-6K-SG02LP1 / SUNSYNK-7.6K-SG02LP1

Global Tech China Ltd, 3 Floor, Wai Yip Industrial Building,
171 Wai Yip Street, Kwun Tong, Kowloon, Hong Kong.
Tel: +852 2884 4318 Fax: +8522884 4816
www.sunsynk.com / sales@globaltech-china.com
www.globaltechhk.com

INDEX

1. SAFETY	4
1.1. GENERAL SAFETY INFORMATION	4
1.2. SYMBOLS	4
1.3. SAFETY INSTRUCTIONS	5
1.4. DISPOSAL REMARKS	5
2. PRODUCT INTRODUCTION	6
2.1. SYSTEM OVERVIEW	6
3. TECHNICAL SPECIFICATIONS	8
3.1. SYSTEM DIAGRAM	9
4. INSTALLATION	10
4.1. SELECTING THE MOUNTING AREA	10
4.2. MOUNTING THE INVERTER	11
4.3. BATTERY CONNECTION	12
4.4. CONNECTING A LITHIUM BATTERY	13
4.5. BATTERY TEMPERATURE CONNECTION	14
4.6. CONNECTING THE AC	16
4.7. INSTALLING THE CT COIL	18
4.8. EARTH CONNECTION (MANDATORY)	20
4.9. CONNECTING THE PV	21
4.9.1. PV MODULE SELECTION	21
4.9.2. PV MODULE WIRING	21
5. OPERATION	23
5.1. DISPLAY	23
5.2. SWITCHING ON/OFF	24
5.3. HOME PAGE	24
5.4. STATUS PAGE	25
5.5. SYSTEM FLOW PAGE	26
5.6. SETUP PAGE	27
5.7. SET TIME (CLOCK)	28
5.8. SET COMPANY NAME / BEEPER / AUTO DIM	28
5.9. FACTORY RESET AND LOCK CODE	29
5.10. BATTERY SETUP PAGE	30
5.11. GENERATOR AND BATTERY PAGE	31
5.12. BATTERY DISCHARGE PAGE	34
5.13. SETTING UP A LITHIUM BATTERY	35
5.14. PROGRAM CHARGE / DISCHARGE TIMES PAGE	38

5.15. GRID SUPPLY VOLTAGE AND FREQUENCY – GRID SUPPLY PAGE	41
5.15.1. REACTIVE POWER SETTING (QV)	41
5.15.2. ACTIVE POWER SETTING (VW):	42
5.15.3. VOLT VARIABLE MODE (VOLT-VAR - VV)	43
5.16. ADVANCED SETTINGS FOR PARALLELING INVERTERS	46
5.17. SOLAR POWER GENERATED	48
5.18. GRID POWER	49
5.19. ADVANCED SETTINGS FOR WIND TURBINE	49
5.20. ADVANCED SETTINGS FOR AUXILIARY LOAD	51
5.21. ADVANCED SETTINGS FOR PEAK POWER SHAVING	52
5.22. FAULT CODES	53
<u>6. COMMISSIONING</u>	<u>57</u>
6.1. STARTUP / SHUTDOWN PROCEDURE	57
6.2. INFORMATION FOR COMMISSIONING THE INVERTER	57
6.3. GDFI FAULT	58
<u>7. MAINTENANCE</u>	<u>59</u>
<u>APPENDIX A</u>	<u>59</u>
<u>APPENDIX B</u>	<u>59</u>
<u>APPENDIX C</u>	<u>60</u>
<u>APPENDIX D</u>	<u>60</u>
<u>APPENDIX E</u>	<u>60</u>



1. SAFETY

1.1. General Safety Information

- This device should only be used in accordance o instructions within this manual and in compliance with local, regional and national laws and regulations. Only allow this device to be installed, operated, maintained, repaired by other persons who have also read and understood this manual. Ensure the manual is included with this device should it be passed to a third party.
- DO NOT allow minors, untrained personnel, or person(s) suffering from a physical or mental impairment that would affect their ability to follow this manual, install, maintain or repair this device.
- Any untrained personnel who might get near this device while it is in operation **MUST** be informed that it is dangerous and instructed carefully on how to avoid injury.



1.2. Symbols

 WARNING	This symbol indicates information that if ignored, could result in personal injury or even death due to incorrect handling.
 CAUTION	This symbol indicates information that if ignored, could result in personal injury or physical damage due to incorrect handling.
NOTICE	Indicates information that is considered important, but not hazard-related.

1.3. Safety Instructions



HIGH LIFE RISK DUE TO FIRE OR ELECTROCUTION.

The Sunsynk Three-Phase Hybrid Inverter can only be installed by a qualified licensed electrical contractor. This is not a DIY product.

- Be sure to read this manual thoroughly before installation.
- Do not attempt to install the inverter by yourself. Installation work must be carried out in compliance with national wiring standards and by suitably qualified personnel only. Do not turn on the power until all installation work is complete.
- Do not disassemble the inverter. If you need repair or maintenance, contact a professional service centre.
- Always use an individual power supply line protected by a circuit breaker and operating on all wires with a distance between contacts of at least 3mm for this unit.
- The unit must be correctly grounded and the supply line must be equipped with a suitable breaker and RCD to protect people.
- Disconnect all wires/cables before performing any maintenance or cleaning to reduce the risk of electrical shock.
- The unit is not explosion-proof, so it should not be installed in an explosive atmosphere.
- Never touch electrical components immediately after the power supply has been turned off since the system can still have residual energy, so electric shock may occur. Therefore, after turning off the power, always wait 5 minutes before touching electrical components.
- This unit contains no user-serviceable parts. Always consult an authorised contractor for repairs.

1.4. Disposal Remarks

DO NOT dispose this product with domestic waste!



Electrical devices should be disposed of in accordance with regional directives on electronic and/ or electronic-waste disposal. In case of further questions, please consult your supplier. In some cases, the supplier can take care of proper disposal.

2. PRODUCT INTRODUCTION

The Sunsynk Three-Phase Hybrid Inverter is a highly efficient power management tool that allows the user to hit those 'parity' targets by managing power-flow from multiple sources such as solar, mains power (grid) and generators, and then effectively storing and releasing power as and when utilities require.

2.1. System Overview

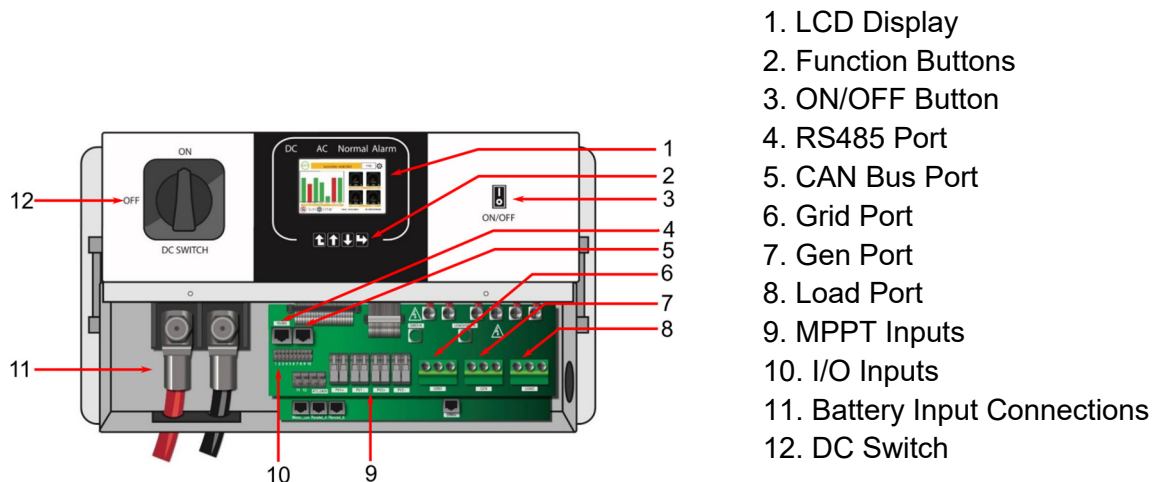

1. LCD Display
2. Function Buttons
3. ON/OFF Button
4. RS485 Port
5. CAN Bus Port
6. Grid Port
7. Gen Port
8. Load Port
9. MPPT Inputs
10. I/O Inputs
11. Battery Input Connections
12. DC Switch

INTERACTIVE

- Easy and simple to understand display
- Supporting Wi-Fi or GSM monitoring
- Visual power flow screen
- Smart settable 3-stage MPPT charging for optimized battery performance
- Auxiliary load function
- Parallel / multi invert function grid-tied and off-grid

COMPATIBLE

- Compatible with main electrical grid voltages or power generators
- Compatible with wind turbines
- 220V single phase, pure sinewave inverter
- Self-consumption and feed-in to the grid
- Auto restart while AC is recovering
- Auto earth bond feature (Via a relay)

CONFIGURABLE

- Fully programmable controller
- Programmable supply priority for battery or grid
- Programmable multiple operation modes: on-grid/off-grid & UPS
- Configurable battery charging - current/voltage based on applications by LCD setting
- Configurable AC / solar / generator charger priority by LCD setting

SECURE

- Overload/over-temperature/short-circuit protection
- Smart battery charger design for optimized battery protection
- Limiting function installed to prevent excess power overflow to grid

APPLICATIONS

- Marine (vessel power management)
- Power shedding (home/office/factory)
- UPS (fuel-saving systems)
- Remote locations with solar and wind generators
- Building sites
- Military locations
- Telecommunication

TECHNICAL SPECIFICATIONS

3. TECHNICAL SPECIFICATIONS

Model	SUNSYNK-6K-SG02LP1	SUNSYNK-7.6K-SG02LP1
Battery Input Data		
Battery Type	Lead-acid or Lithium-ion	
Battery Voltage Range	40~60V	
Max. Charging Current	135A	190A
Max. Discharging Current	135A	190A
Charging Curve	3 Stages/Equalisation	
External Temperature Sensor	Optional	
Charging Strategy for Li-Ion Battery	Self-Adaptation to BMS	
PV String Input Data		
Max. DC Input Power	7800W	9880W
PV Input Voltage	370V (100V~500V)	
MPPT Range	125~425V	
Start-up Voltage	150V	
PV Input Current	18A+9A	22A+22A
No. of MPPT Trackers	2	
No. of Strings Per MPPT Tracker	2+1	2+2
AC Output Data		
Rated AC Output and UPS Power	6000W	7600W
Max. AC Power	6600W	8360W
Peak Power (off-grid)	2 times of rated power, 10 S	
AC Output Rated Current	25A	31.7A/33A
Max AC Output Current	27.5A	34.9A/36.3A
Max Continuous AC Passthrough	40A	50A
Output Frequency and Voltage	50/60Hz; 120/240Vac(split phase), 208Vac(2/3), 230Vac(single phase)	
Grid Type	Split phase, 2/3 phase, Single phase	
Current Harmonic Distortion	THD<3%(Linear load<1.5%)	
Efficiency		
Max. Efficiency	97.60%	
MPPT Efficiency	96.50%	
Euro Efficiency	99.90%	
Protection		
PV Arc Fault Detection	Integrated (Except European Type)	
PV Input Lightning Protection	Integrated	
Anti-islanding Protection	Integrated	
PV String Input Reverse Polarity Protection	Integrated	
Insulation Resistor Detection	Integrated	
Residual Current Monitoring Unit	Integrated	
Output Over Current Protection	Integrated	
Output Shorted Protection	Integrated	
Output Over Voltage Protection	Integrated	
Certifications and Standards		
Grid Regulation	UL1741, IEEE1547, RULE21, VDE0126, AS4777, NRS2017, G98,G99, IEC61683, IEC62116, IEC61727	
Safety Regulation	IEC62109-1, IEC62109-2	
EMC	EN61000-6-1, EN61000-6-3, FCC 15 Class B	
General Data		
Operating Temperature Range	-25~60°C, >45°C Derating	
Cooling	Fan	
Noise	<30	
Communication with BMS	RS485; CAN	
Warranty	5 years	

3.1. System Diagram

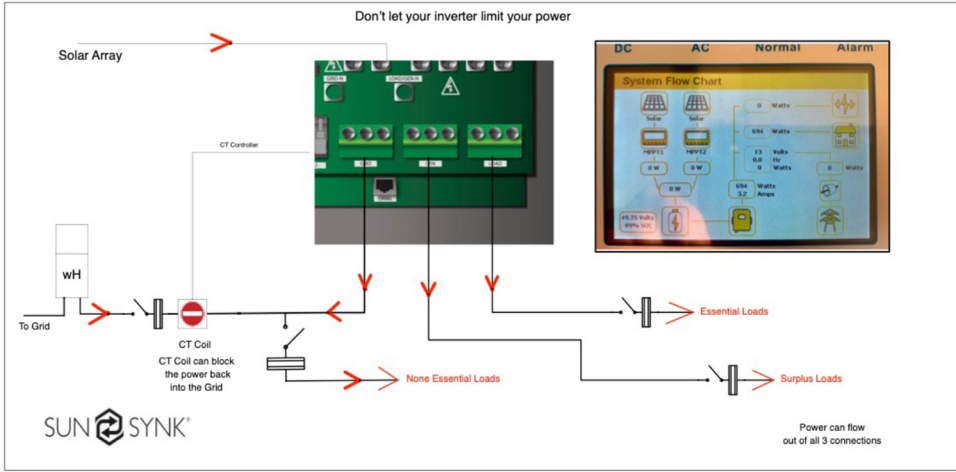
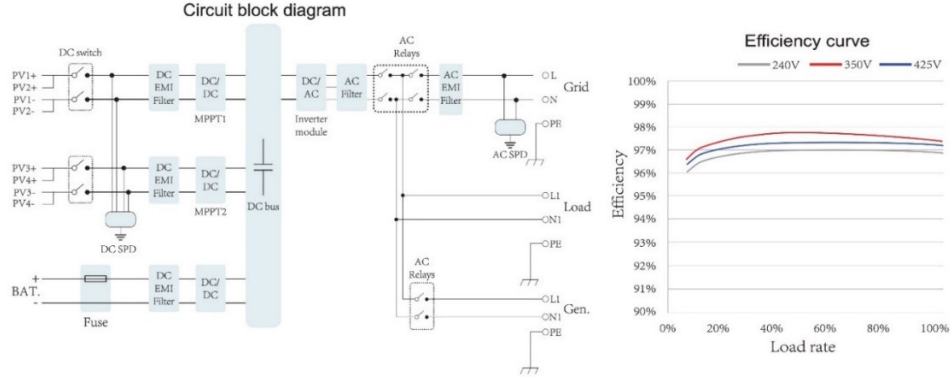

4. INSTALLATION

4.1. Selecting the Mounting Area



DO NOT install the inverter in the following areas:

- Areas with high salt content, such as the marine environment. It will deteriorate the metal parts and possibly lead to water/dampness penetrating the unit.
- Areas filled with mineral oil or containing splashed oil or steam such as found in kitchens. It will deteriorate plastic parts of the unit, causing those parts to fail or allow water/damp to penetrate the unit.
- Areas that generate substances that adversely affect the equipment, such as sulphuric gas, chlorine gas, acid, or alkali. These can cause the copper pipes and brazed joints to corrode and fail to conduct electricity reliably.
- Areas that can cause combustible gas to leak, which contains suspended carbon-fibre or flammable dust, or volatile inflammable such as paint thinner or gasoline.
- Areas where there may be gas leaks and where gas may settle around the unit as this is a fire risk.
- Areas where animals may urinate on the unit or ammonia may be generated.
- High altitude areas (over 4000 metres above sea level).
- Environments where precipitation or humidity are above 95%
- Areas where the air circulation is too low.

ALSO CONSIDER:

- Installing the indoor unit, outdoor unit, power supply cable, transmission cable, and remote control cable at least 1 metre away from any television or radio receiver. This will prevent TV reception interference or radio noise. This will prevent radio signal interference from external units that might interfere with the Wi-Fi or GSM monitoring.
- If children under 10 years old may approach the unit, take preventive measures so that they cannot reach and touch the unit.
- Install the indoor unit on the wall where the height from the floors is higher than 1600mm.
- For proper heat dissipation, allow a clearance of approximately 500mm to the side, 500mm above and below the unit, and 1000mm to the front of the unit.

4.2. Mounting the Inverter

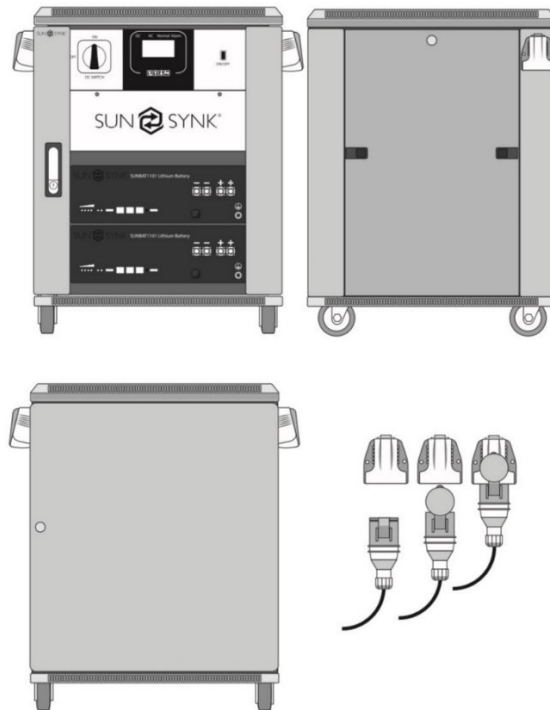

- An appropriate ambient temperature is between $-25 \sim 60^{\circ}\text{C}$ to ensure optimal operation.
- Be sure to keep other objects and surfaces as shown in the figure to guarantee sufficient heat dissipation and have enough space to remove wires.
- For proper air circulation to dissipate heat, allow a clearance of approximately 50cm to the side.

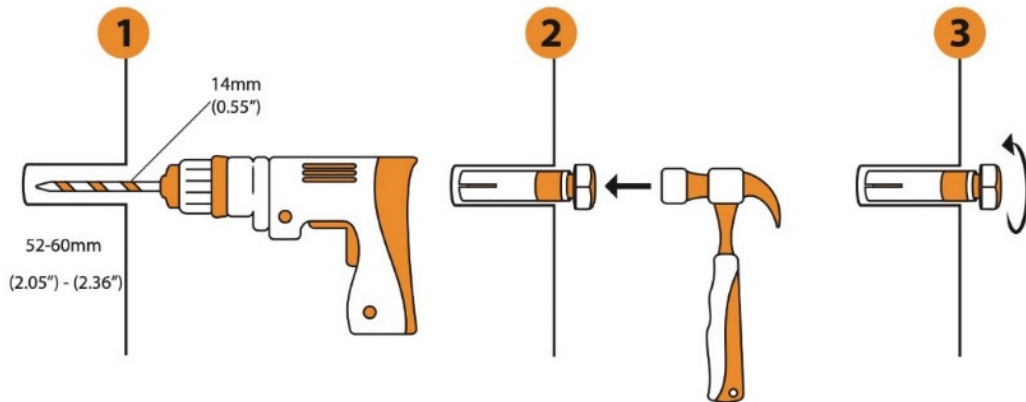

CAUTION

Risk of injury (Heavy Object)

Remember that this inverter is heavy so users must be careful in handling the unit during installation.

4.3. Battery Connection

■ Battery connection

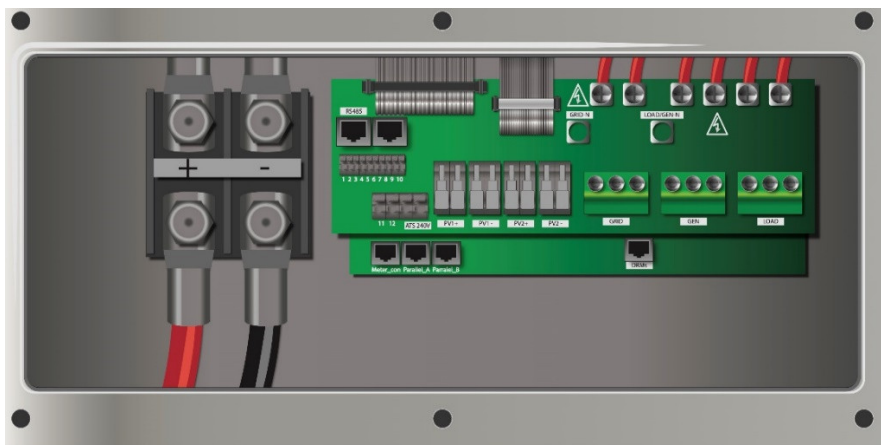

For safe operation and compliance, an individual DC overcurrent protector or disconnection device is required for the connection of the battery and the inverter. Users are recommended to utilise a suitable fuse and DC isolator (see next page). In some applications, switching devices may not be required, but overcurrent protectors must be used. Please refer to the typical amperage in the table below for the required fuse or circuit breaker size.

A minimum battery cable size of 50mm diameter is recommended for the 6kW and 7.6kW inverters.



CAUTION

All wiring/connecting must be performed by qualified personnel. Before making the final DC connection or closing the DC Breaker/disconnection device, ensure the inverter unit is wired correctly. A reverse-polarity connection on the battery will damage the inverter.

■ Recommended DC Surge Protector:

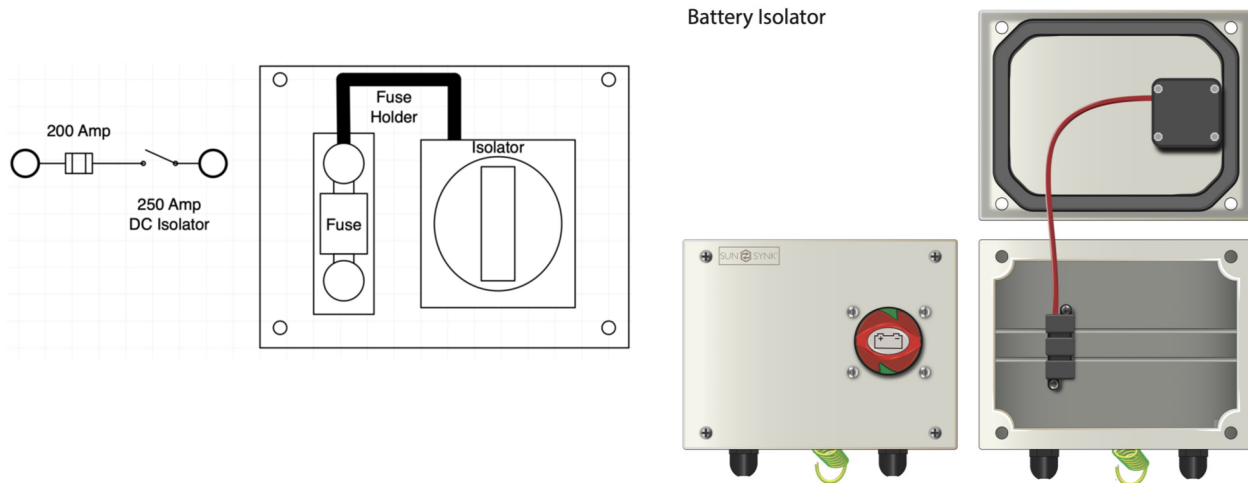

4.4. Connecting a Lithium Battery

When connecting a Lithium battery, follow the connection steps below and check 'Setting up a Lithium Battery' to connect with an inverter.

- 1) Connect the correct diameter of cable in accordance with the battery manufacture specifications along with recommended safety devices.
- 2) Connect a communication cable from the batteries to the inverter in compliance with the battery manufacturer guidelines. The cables have two ends, one to be specifically connected to the BMS and another to be connected to the inverter, do not connect them incorrectly.
- 3) Connect the power and communication cables to the inverter correctly.

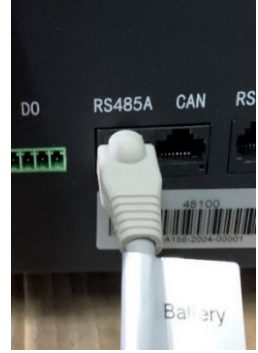

NOTICE

When connecting more than one battery, ensure they are set in the configuration of 'master and slave'.

4.5. Battery Temperature Connection

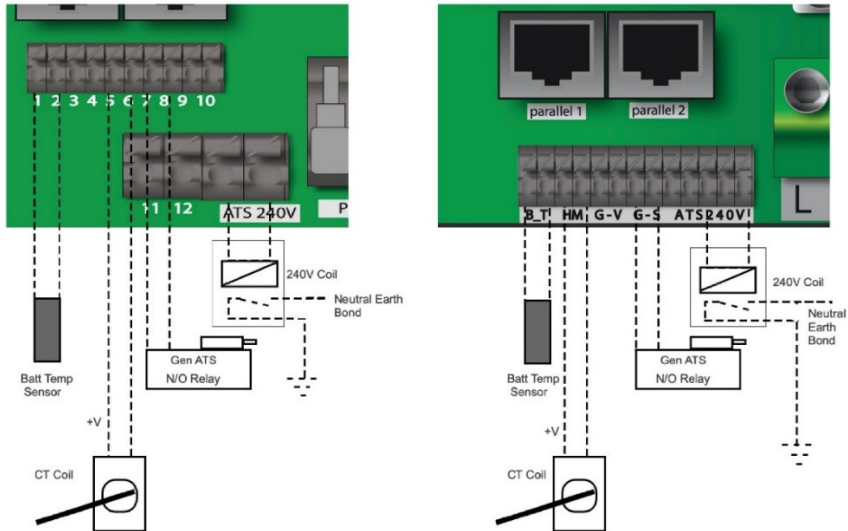

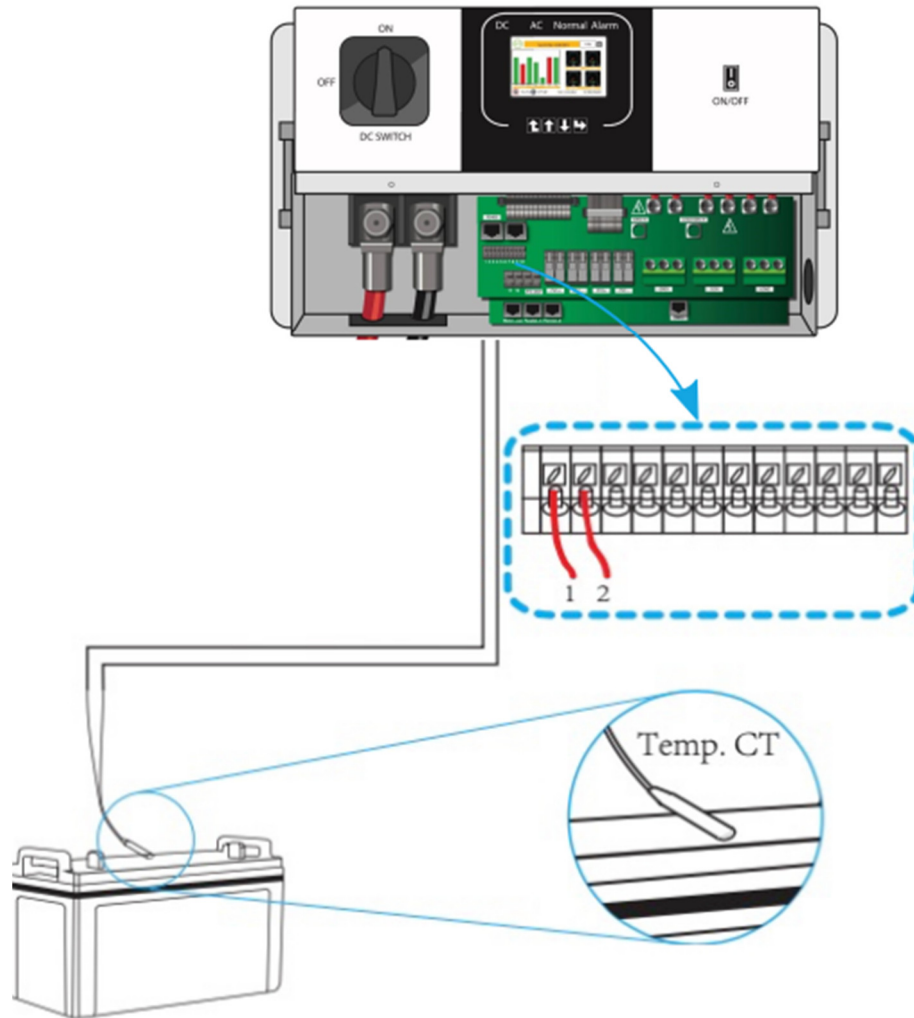

Without a remote temperature sensor, lead-acid batteries may undercharge or overcharge depending on the ambient temperature of the installation environment. This may result in a fire hazard.

NOTICE

Depending on the battery type, the inverter should be capable of controlling the batteries BMS. Therefore, you need to set the protocol of the BMS on both the battery and the inverter.

When using more than one battery, the first battery will be the master, and the other batteries will be the slaves. Please, check the battery manufacturer specification for proper operation.

To verify if the battery is actually communicating access the Li BMS menu as detailed in section 'Setting Up a Lithium Battery' and check whether the values are realistic or not. It is important that the charge and discharge limits in that page match the numbers expected for the number of batteries physically connected.

4.6. Connecting the AC

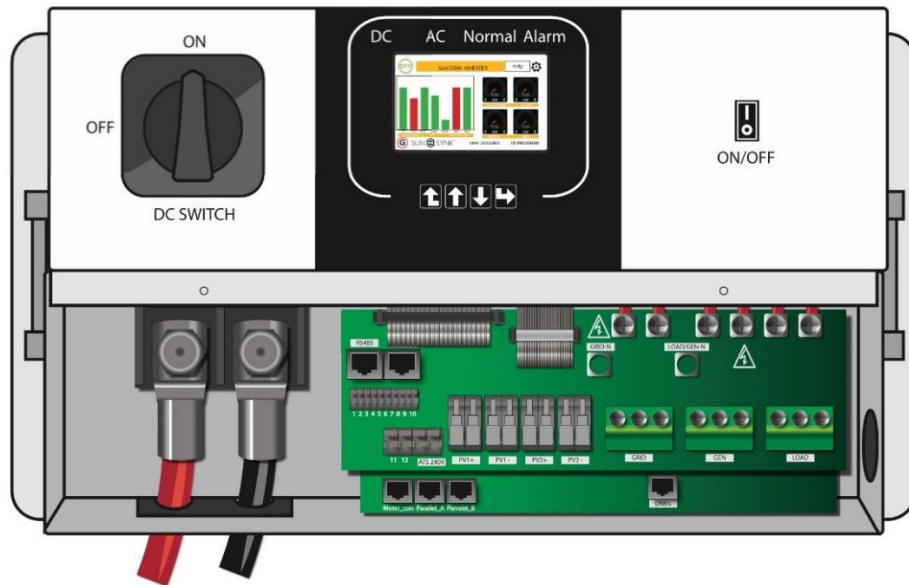

GEN/AUX	Generator connection.
GRID	This works like a conventional grid-tied inverter. It is both an input and output connection for non-essential load and supply
LOAD	Connection of essential loads such as lighting, security systems, and Internet

CAUTION

All wiring and cable sizes must comply with your particular country's wiring regulations and Codes of Practices

Ensure that suitable disconnection devices and RCDs are fitted.

Please follow the steps below to implement GRID, LOAD, and GEN port connections:

- 1) Before making GRID, LOAD, and GEN port connections, make sure to turn off the AC breaker or disconnecter first.
- 2) Remove 10mm sleeve from each wire, unscrew the bolts, insert the wires according to the polarities indicated on the terminal block and tighten the terminal screws. Ensure the connection is complete.

- 3) Then, insert AC output wires according to polarities indicated on the terminal block and tighten the terminal. Make sure to connect corresponding N wires and PE wires to related terminals as well.
- 4) Ensure the wires are securely connected.
- 5) Check that the AC power source is isolated before attempting to connect it to the inverter. Insert AC output wires according to the polarities indicated on the terminal block and tighten the terminal screws. Be sure to connect corresponding N wires and PE wires to the correct terminals and ensure the wires are securely connected.

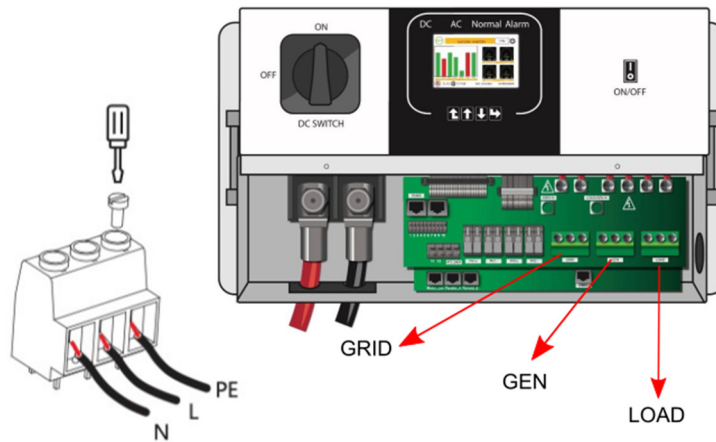

■ Recommended AC Surge Protector

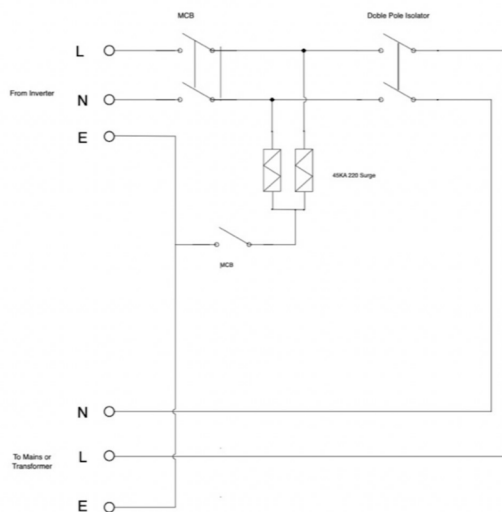

Mains Surge Protector

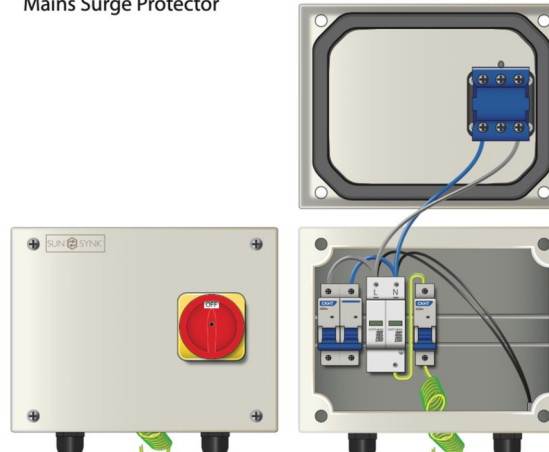

Please ensure you use suitable protection devices. Switchgear and fuses must be following the local wiring standards. A figure of the complete system is presented below.

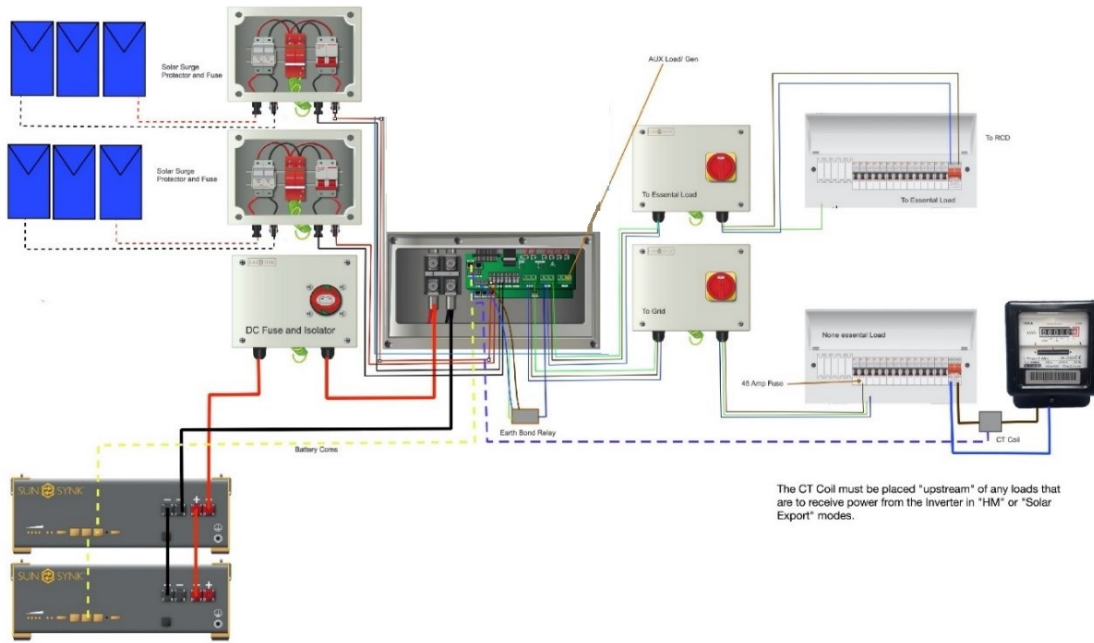

4.7. Installing the CT Coil

The CT coil is one of the most important parts of the Sunsynk Parity inverter. This device reduces the power of the inverter to prevent feeding power to the grid. This feature is also known as "Zero Export".

- 1) Fit the coil (sensor) around the live cable on the main fuse feeding the building and run the cable back to the inverter. This cable can be extended up to an extra 10m using a similar cable.
- 2) Connect the other end of the CT coil into the inverter terminals marked as CT coil.

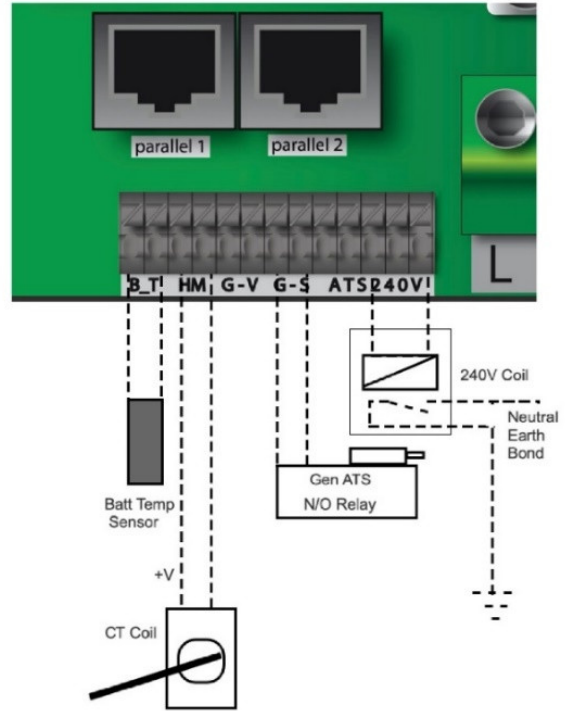
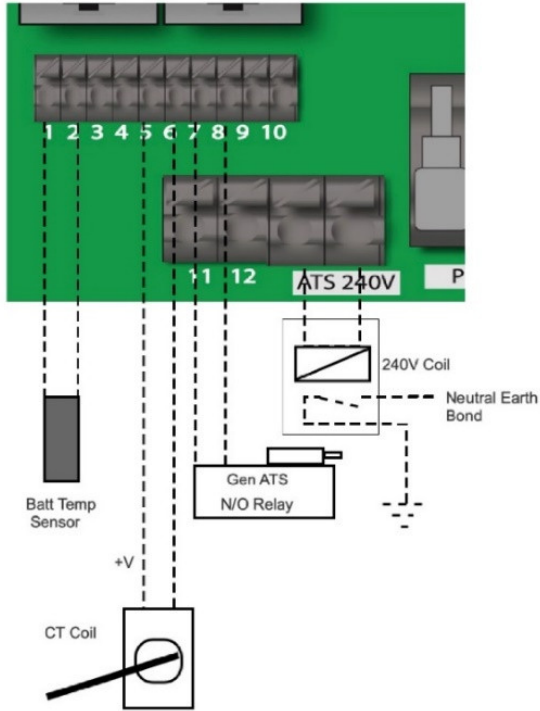

0 Watts 0.00 V 0.00 Amps 0.0 C	0 watts 0 Hz 0 Volts 0.0 Amps CT:0Watts LD: 0Watts	0 Watts 0.00 Volts 0.0 Amps
Battery	Grid Power	Solar Power 1
0 watts 0 Hz 0 Volts 0.0 Amps DC:100.0 C AC:100.0 C	0 Watts 0.00 Volts 0.0 Amps	0 Watts 0.00 Volts 0.0 Amps
Inverter Power	Load Power	Solar Power 2

IMPORTANT

If the CT coil is fitted in the wrong way then this variable will have negative instead of positive values when the power is flowing into the house/inverter. Also, the inverter export limiting function will not work properly.

4.8. Earth Connection (MANDATORY)

An Earth Cable shall be connected to earth plate on the grid size in order to prevent electric shock if the original protective conductor fails.

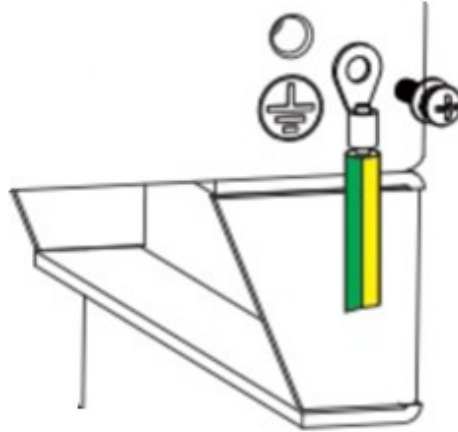

All neutrals can be linked together to maintain the neutral bond. When Neutral Earth bond is required for 'Off-grid' operation, then it has to be removed on 'Grid-Tied' operation.

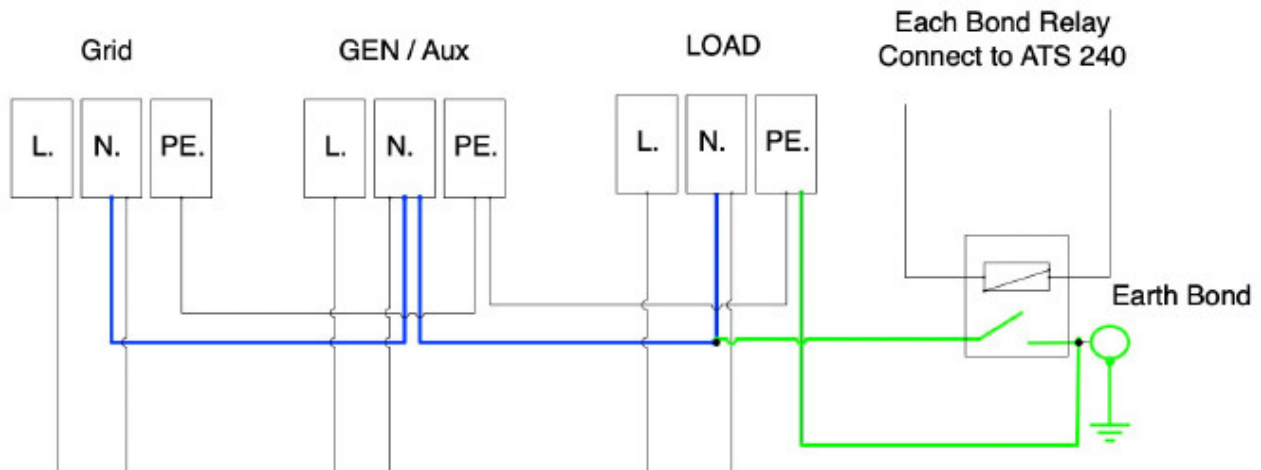

If an Earth Bond is required between neutral and earth and your system is a hybrid system then you can have a permanent earth wire since this can cause faults with an RCD before the inverter.

Since the inverter is a true hybrid then the bond must only be made when the inverter is operating in Islanding Mode. To accommodate this, Sunsynk provides an AC output, which is connected to the A/T/S connections whenever the inverter is running on Island Mode. Therefore, you can simply connect the coil of an AC relay to the ATS 240 connections. Next, you need to select Signal Island Mode on the battery charge menu (click on the gear icon -> battery icon), as shown in the figure below.

NOTICE

The grid power may still be present, but the inverter is not draining power from it since the unit is working in 'Island Mode'.

You can verify if there is a voltage when the inverter is disconnected from the grid by using a simple multimeter.

4.9. Connecting the PV

Before connecting to PV panels, install a separate DC circuit breaker between the inverter and PV modules. In addition, we request users install PV junction box with surge protection to protect the system from lightning strike.

To avoid any malfunction, do not connect any PV modules with possible current leakage to the inverter. For example, grounded PV modules will cause current leakage to the inverter.

4.9.1. PV Module Selection

When selecting the PV modules, you should consider the following parameters:

- 1) Open-Circuit Voltage (Voc) of PV modules does not exceed the maximum PV array Voc.
- 2) Open-Circuit Voltage (Voc) of PV modules should be higher than minimum start voltage of the inverter.

4.9.2. PV Module Wiring

- 1) Switch the Grid Supply Main Switch (AC) OFF.
- 2) Switch the DC isolator OFF.

3) Assemble PV input connector to the inverter.

CAUTION

Before connection, please ensure the polarity of the output voltage of PV array matched the DC+ and DC- symbols.

WARNING

Please do not connect the PV array positive and negative pole to the ground. This can seriously damage the inverter.

Before connecting the inverter, please make sure the PV array open-circuit voltage is within the maximum limit of the inverter.

PV Connection:

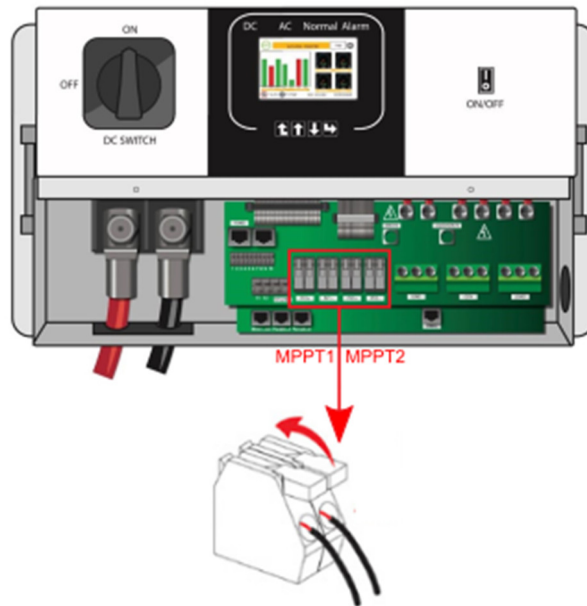

NOTICE

When sunlight falls on the solar panel, it will generate a voltage. A high voltage generated by panels in series configuration may cause danger to life. Therefore, before connecting the DC-Input line, the solar panel's surface should be shielded from the sun's rays by some opaque material and the DC switch should be off. This will prevent a high voltage flowing to the inverter thereby causing risk to persons conducting installation or maintenance.

5. OPERATION

5.1. Display



LED indicator		Meaning
DC	Green LED solid light	PV connection normal
AC	Green LED solid light	Grid connection normal
Normal	Green LED solid light	Inverter functioning normally
Alarm	Red LED solid light	Fault

Function Key	Description
Esc	To exit the previous mode
Up	Increase the value of a setting
Down	Decrease the value of a setting
Enter	Confirm setting change (If not pressed each time the setting will not be saved)

5.2. Switching ON/OFF

Once the inverter has been correctly installed and the batteries have been connected, press the ON/OFF button (located on the left side of the case) to activate the system.

When the system is connected without a battery but connected with either PV or grid and the ON/OFF button is switched off, the LCD will still illuminate (display will show off). In this condition, when switching on the ON/OFF button and selecting 'No Battery', the system can still work.

5.3. Home Page

Press the Esc button any page to access the home page:

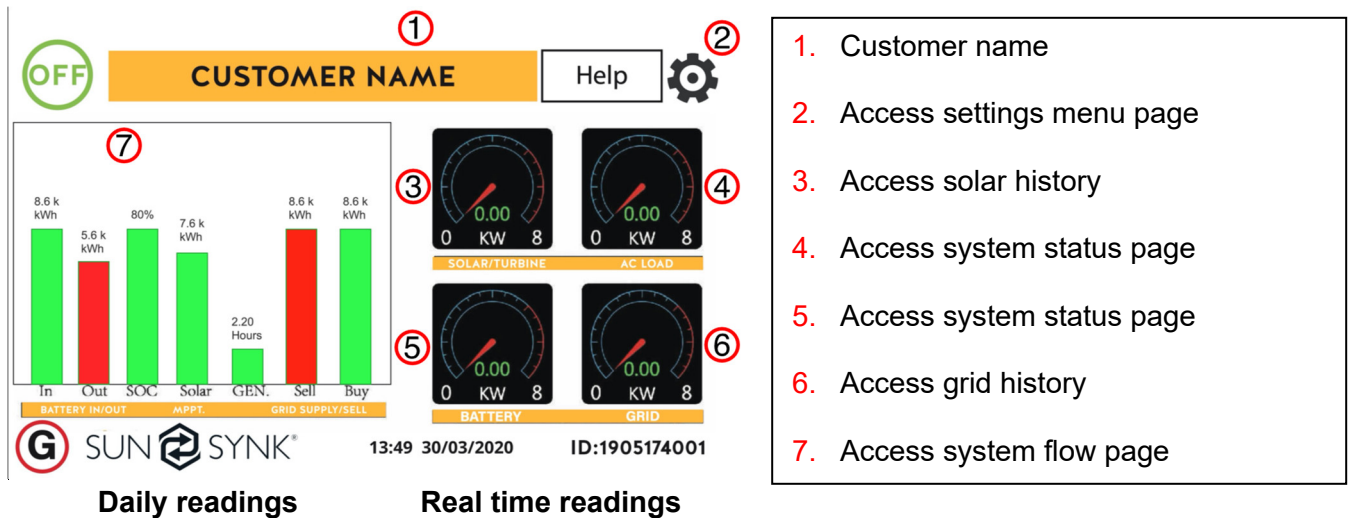

1. Customer name
2. Access settings menu page
3. Access solar history
4. Access system status page
5. Access system status page
6. Access grid history
7. Access system flow page

What this page displays:

- Total daily power into the battery (kWh).
- Total daily power out of the battery (kWh).
- SOC (State of charge of the battery) (%).
- Total daily solar power produced in (kWh).
- Total hourly usage of the generator (Time).
- Total daily power sold to the grid (kWh).
- Total daily power bought from the grid (kWh).
- Real-time solar power in (kW).
- Real-time load power in (kW).
- Real-time battery charge power in (kW).
- Real-time grid power in (kW).
- Serial number.
- Time date.
- Fault condition.
- Access stats pages.
- Access status page.
- Access fault diagnostic page.

5.4. Status Page

To access the Status page, click on the BATTERY or AC LOAD dial on the Home page.

What this page displays:

- Total solar power produced.
- MPPT 1 power/voltage/current.
- MPPT 2 power/voltage/current.
- Grid power.
- Grid frequency.
- Grid voltage.
- Grid current.
- Inverter power.
- Inverter frequency.
- Inverter voltage.
- Inverter current.
- Load power.
- Load voltage.
- Battery power charge/discharge.
- Battery SOC.
- Battery voltage.
- Battery current.
- Battery temperature.

0 Watts 0.00 V 0.00 Amps 0.0 C	0 watts 0 Hz 0 Volts 0.0 Amps CT:0Watts LD: 0Watts	0 Watts 0.00 Volts 0.0 Amps
Battery	Grid Power	Solar Power 1
0 watts 0 Hz 0 Volts 0.0 Amps DC:100.0 C AC:100.0 C	0 Watts 0.00 Volts 0.0 Amps	0 Watts 0.00 Volts 0.0 Amps
Inverter Power	Load Power	Solar Power 2

Solar Column: Shows total PV (Solar) power at the top and then details of each of the two MPPT's below L1 & L2 voltage.

Grid Column: Shows grid total power, frequency, voltage, and current. When selling power to grid the power is negative. When consuming from the grid the power is positive. If the sign of the grid and HM (home) powers are not the same when the PV is disconnected and the inverter is only taking energy from the grid and using the CT connected to Limit-2, then please reverse the polarity of the CT coil. **Important:** See Section 4.6 ('Connecting the CT coil').

Inverter Column: Showing inverter total power, frequency, L1, L2, voltage, current, and power.

Load Column: Showing total load power, load voltage, and power on L1 and L2.

Battery Column: Showing total power from the battery, battery SOC, battery voltage, battery current (negative means charge, positive means discharge) battery temperature (shows zero if the battery temperature sensor is not connected). DC transformer temperature and AC heatsink temperature (When the temperature reaches 90°C it will display in red and the performance of the inverter will start deteriorating when it reaches

110°C. Subsequently, the inverter will shut down to allow it to cool and reduce its temperature.

5.5. System Flow Page

Access by clicking on the bar chart on the Home Page.

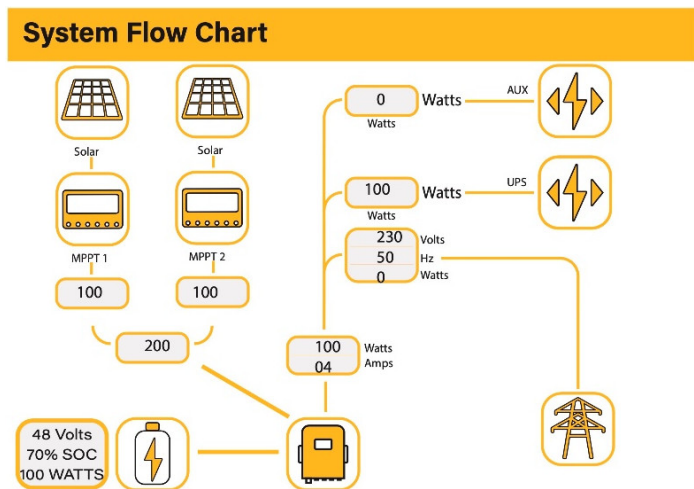

What this page displays:

- The system flow.
- MPPTs power.
- Battery status.
- Power distribution to load or grid.

To better understand the functioning of your system, take a look at the figure bellow:

1. The PV modules charge the batteries.
2. When the batteries reach a specific level (programmable) the battery power is fed into the inverter.
3. The inverter can then supply power to the grid (export or no export), load, and auxiliary or smart load.
4. CT coil controls the export power.

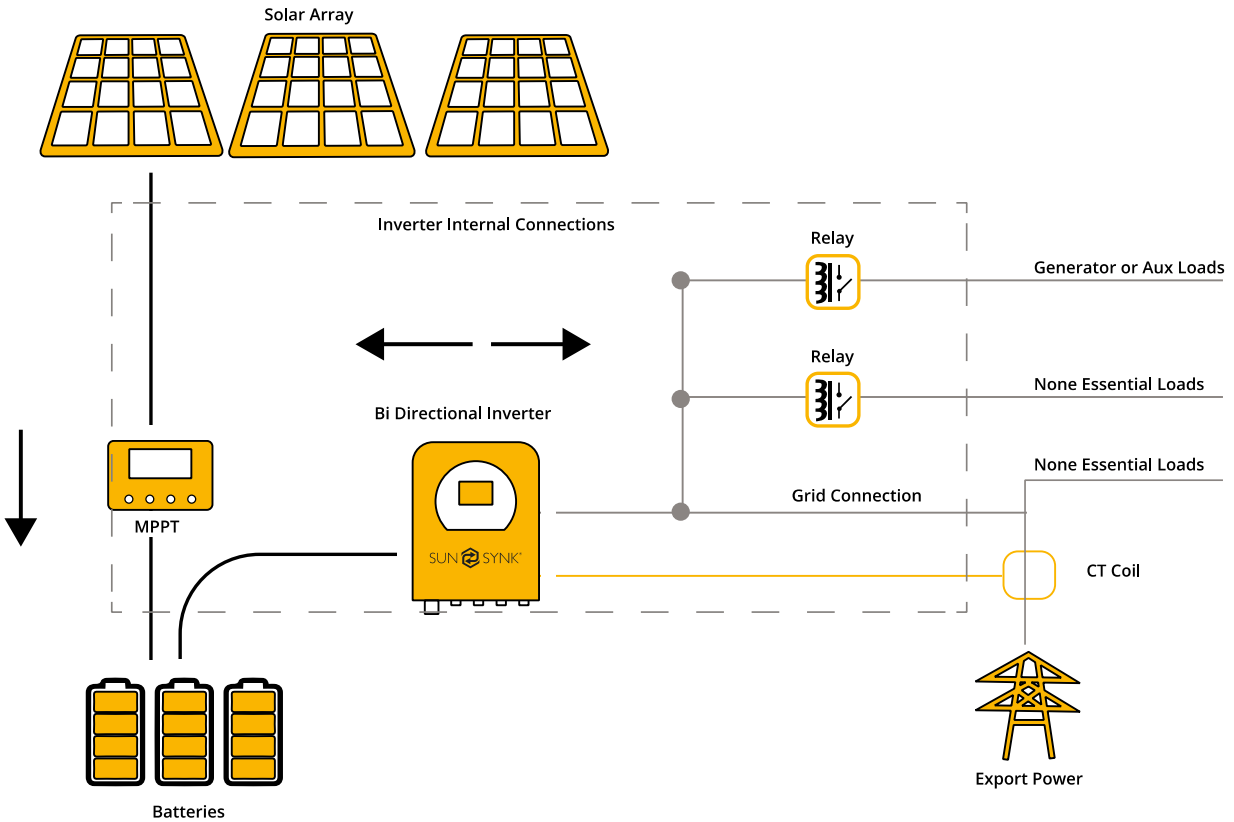

5.6. Setup Page

To access the Settings, click on the gear icon



on the right top of the navigation menu.

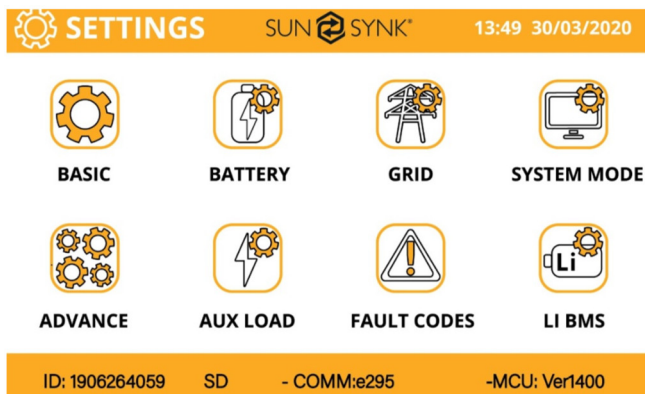

What this page displays:

- Serial number.
- Software version.
- Time, Date, and MCU.

What you can do from this page:

- Access the Basic Setup Page (press the BASIC icon).
- Access the Battery Setup Page (press the BATTERY icon).

- Access the Grid Setup Page (press the GRID icon).
- Access the real-time programmable timer/system mode (press the SYSTEM MODE icon).
- Access the advanced settings such as Paralleling and Wind Turbine (press the ADVANCE icon).
- Access the auxiliary load/smart load settings (press the AUX LOAD icon)
- Access the fault code register (press the FAULT CODES icon).
- Set up Li BMS (press the LI BMS icon).

5.7. Set Time (Clock)

To set time, click on the BASIC icon and then on 'Time'.

Basic Setup		Help		
Time	Display	Reset		
<input type="checkbox"/> Sync	Year	Month	Day	
	2018	10	24	
<input type="checkbox"/> AM/PM	Hour	Minute	Second	
	01	53	17	
Cancel		OK		

What this page displays:

- Time.
- Date.
- AM/PM.

What you can do from this page:

- Adjust / set time.
- Adjust / set date.
- Adjust / set AM/PM.

How to set up (step-by-step):

1. Touch the screen on the box you wish to change.
2. Change the number (increase/decrease) using the UP and DOWN buttons.
3. Press OK to set the changes.

5.8. Set Company Name / Beeper / Auto dim

To set company name click on the BASIC icon and then on 'Display'.

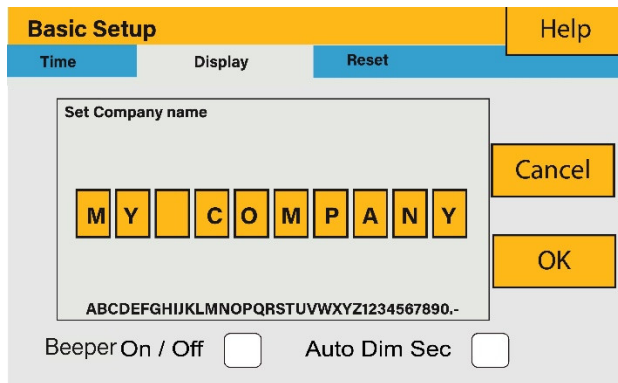

What this page displays:

- Beeper status (ON/OFF).
- Installers names.

What you can do from this page:

- Set up your company name.
- Switch the beeper ON or OFF.
- Set the LCD backlight to auto dim.

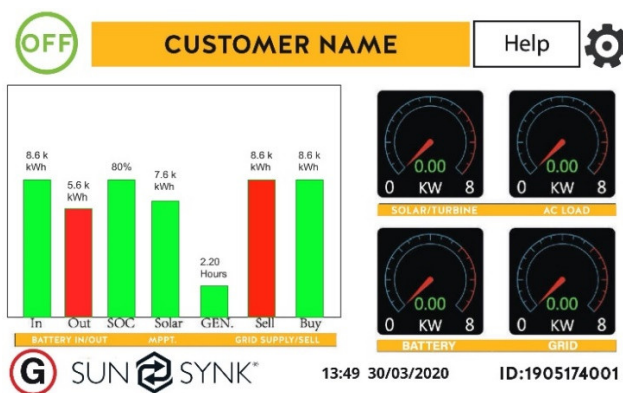

How to change the name:

Change the letters in each box by moving the arrows up and down and then select OK. This will change the name on the home screen.

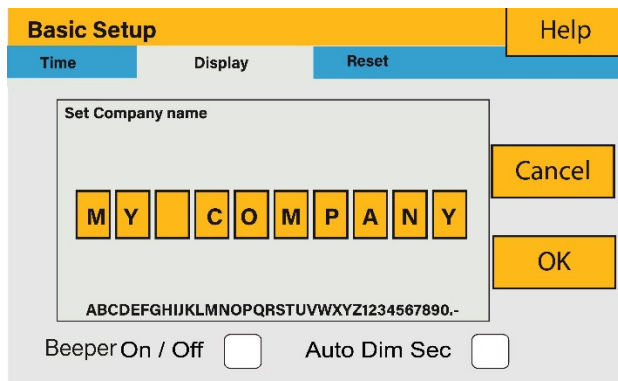

How set the auto dim:

Set a number in the auto dim box to dim the LCD after a number of seconds.

How to turn the beep on or off:

Mark or unmark the beep box and the press OK to configure it as you prefer.

5.9. Factory Reset and Lock Code

To set time, click on the BASIC icon and then on 'Reset'.

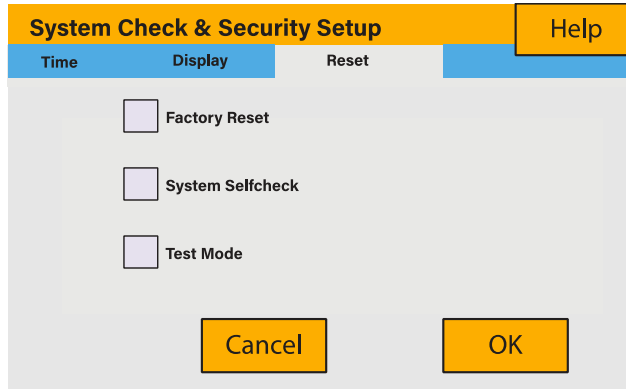

What this page displays:

- Reset status.
- Whether the 'lock code' is used or not.

What you can do from this page:

- Reset the inverter to the factory settings.
- System diagnostics.
- Change or set the 'lock code'.

Factory Reset: Reset all parameters of the inverter

Lock out all changes: Enable this menu to set parameters that before the unit is locked and cannot be reset.

*Before performing a successful 'Factory Reset' and locking the systems the user must enter a password to allow the setting to take place. The password for 'Factory Reset' is 9999 and for lock out is 7777.

System self-check: Allows the user to conduct a system diagnosis.

Test mode (only for engineers): For engineers to conduct tests.

5.10. Battery Setup Page

To configure battery settings, click on the BATTERY icon and then on 'Batt type'.

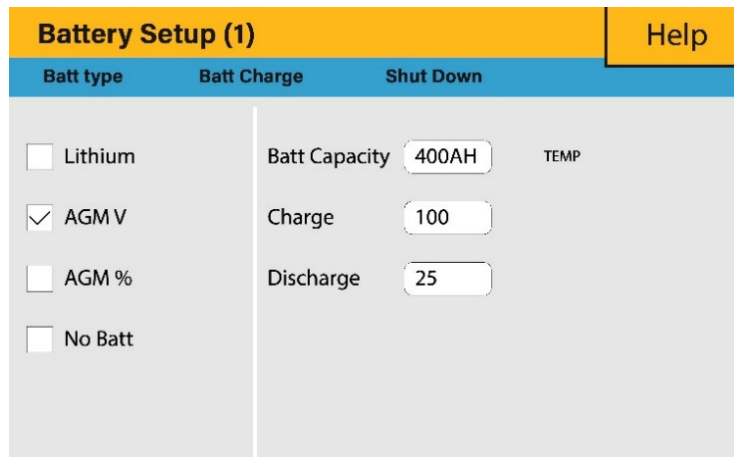

What this page displays:

- Battery capacity in (Ah) – For non-BMS-batteries the range allowed is 0-2000Ah, while for lithium-ion the inverter will use the capacity value of the BMS.
- Max battery charge current (Amps).

- Max battery discharge current (Amps), which should be 20% of the Ah rating for AGM only. For Lithium, please refer to the battery manufacturer documentation. **Note:** This is a global max. discharge current for both 'grid-tied' and 'backup' modes of operation and if the current exceeds this value inverter will shut down with an overload fault.
- TEMPCO settings - Temperature coefficient is the error introduced by a change in temperature.

What you can do from this page:

- Use battery voltage for all settings (V).
- Use battery SOC for all settings (%).
- No battery: tick this box if no battery is connected to the system.
- BMS setting.
- Active battery - This feature will help recover a battery that is 100% discharged by slowly changing from the solar array. Until the battery reaches a point where it can change normally.

5.11. Generator and Battery Page

To configure battery charging settings, click on the BATTERY icon and then on 'Batt Charge'.

The screenshot shows the 'Battery Setup' page with three tabs: 'Batt type', 'Batt Charge', and 'Shut Down'. The 'Batt Charge' tab is active. The page contains several input fields and checkboxes:

- Amps:** Two input fields, both set to '0A'.
- Gen Charge:** A checkbox that is unchecked.
- Grid Charge:** A checkbox that is unchecked.
- Gen Signal:** A checkbox that is unchecked.
- Grid Signal:** A checkbox that is unchecked.
- Signal Island Model:** A checkbox that is unchecked.
- Float V:** An input field set to '0.0V'.
- Absorption V:** An input field set to '0.0V'.
- Equalization V:** An input field set to '0.0V'.
- Equalization Time:** An input field set to '0 days'.
- Equalization Duration:** An input field set to '0.0 hours'.
- GEN MAX RUN TIME:** An input field set to '0.0 hours'.
- GEN DOWN TIME:** An input field set to '0.0 hours'.

At the bottom right, there are 'Cancel' and 'OK' buttons.

What this page displays:

- Generator start voltage/SOC %.
 - Grid power start voltage/SOC %.
 - Float V is the voltage at which a battery is maintained after being fully charged.
 - Absorption V the level of charge that can be applied without overheating the battery.
- Float V for an AGM battery is 55.20V.
 - Absorption V is for an AGM battery is 57.60V.
 - Equalization V for an AGM battery is 58.80V.
 - Equalizing charge/overcharge to remove sulphate crystals that build-up on the plates over time on lead-acid batteries.

What you can do from this page:

- Tick 'Gen Charge' to charge the batteries from the gen I/P.
- Tick 'Grid Charge' to charge the batteries from the grid I/P.
- Tick 'Gen Signal' signal to auto-switch a relay box.
- Tick 'Grid Signal' signal to auto-switch a relay box.

NOTICE

Do not alter these settings too many times on the same battery as it may damage the battery.

Gen Charge: Uses the GEN input of the system to charge battery bank from an attached generator.

Gen Signal: Normally open (NO) relay that closes when the Gen Start signal state is active.

Gen Max Run Time: This indicates the longest time the generator can run in one day. When the maximum running time is reached, the generator will be turned off. '24H' means the generator will run continuously.

Gen Down Time: This indicates the delay-time of the generator to shut down after it has reached the running time

Grid Charge: It indicates that the grid will charge the battery.

Grid Signal: Indicates when the grid should no longer charge the battery.

Recommended battery settings:

Battery Type	Absorption Stage	Float Stage	Voltage (every 30 days 3hr)
AGM (or PCC)	14.2V (57.6V)	13.4V (53.6V)	14.2V (57.6V)
Gel	14.1V (56.4V)	13.5V (54.0V)	
Wet	14.7V (59.0V)	13.7V (55.0V)	14.7V (59.0V)
Lithium	Follow its BMS voltage parameters		

Using a generator with a Sunsynk inverter:

A generator can either be connected to the Grid side or to the Gen connection. When connected to the Grid Input, the inverter will consider the power coming from the generator as 'Grid Supply'. Users should make sure this power goes to the LOAD only and should not be exported to other outlets as this will damage the generator.

An advantage from connecting the generator to the Grid Input is that it can be paralleled whereas the GEN/AUX input cannot be paralleled. That means the inverter will extract what power it requires from 'Grid Supply' to charge its batteries. If the generator is connected to the inverter and a generating signal exists, the inverter will switch 100% of the load to the generator and then slowly increase the charging currents to the batteries. Therefore, the generator must be able to supply both the charge current and the total load current.

The generator can be controlled via a relay which has a set of dry-contacts to enable remote control. The current on these contacts is limited to approximately, 1Amp 12V.

Below is a simple reference circuit of an auto start system that can autostart generators on a boat. (Sunsynk will be releasing a new OS E406 (Auto-Start) for better generator control)

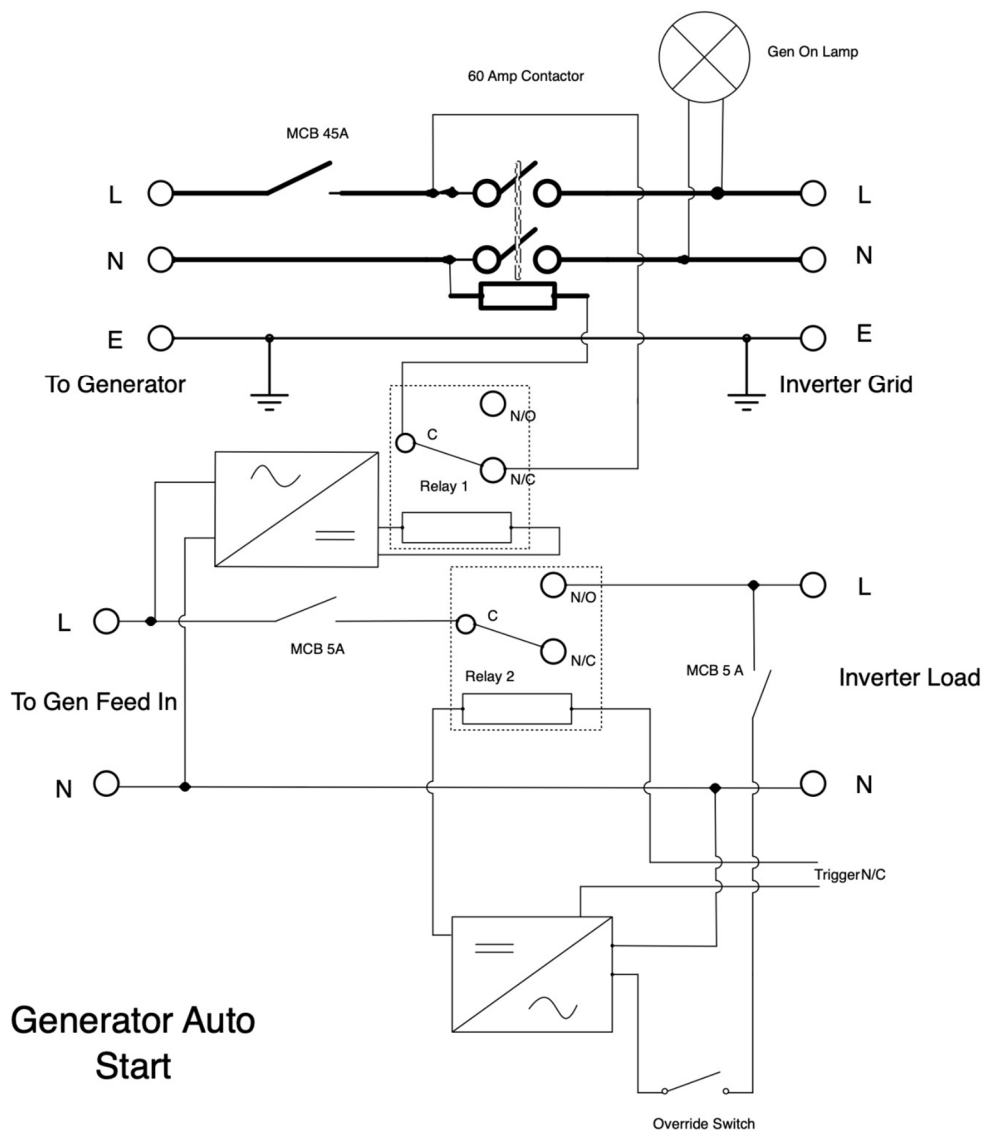

5.12. Battery Discharge Page

To configure inverter's shutdown settings, click on the BATTERY icon and then on 'Shut Down'.

The screenshot shows the 'Battery Setup' interface with three input fields: 'Shutdown' set to 41.0V, 'Low Batt' set to 45.0V, and 'Restart' set to 52.0V. There are 'Cancel' and 'OK' buttons at the bottom.

What this page displays:

- Inverter shutdown voltage set as either a voltage or %.
- Inverter low battery warning set as either a voltage or %.
- Restart voltage set as either a voltage or %.

What you can do from this page:

- Adjust battery shut down (voltage or %)
- Adjust low battery warning (voltage or %)
- Adjust restart (voltage or %)

NOTICE

Activating Shutdown causes the inverter to enter standby-mode. It does not completely shut down the inverter. Total shutdown occurs at voltages below 19V.

The voltage displayed on the Sunsynk Parity Inverter will vary depending on whether the inverter is charging or discharging the batteries.

SUNSYNK PARITY INVERTER CHARGE VOLTAGE

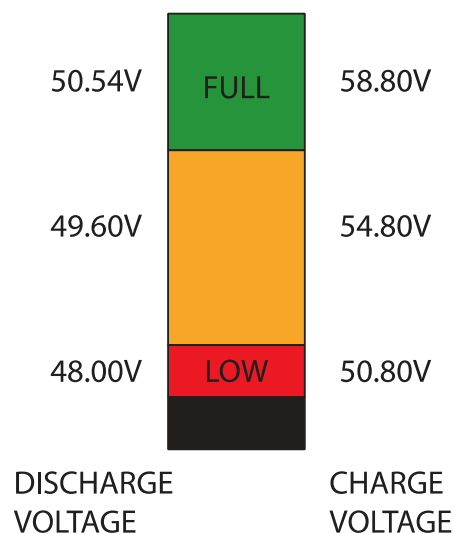

Since the batteries are 48V the figure on the left is x4:

- Fully Charged 50.54V (Discharge Mode)
- Fully Charged 58.50V (Charge Mode)
- 75% Charged 49.60V (Discharge Mode)
- 75% Charged 54.80V (Charge Mode)
- 25% Charged 48.00V (Discharge Mode)
- 25% Charged 50.80V (Charge Mode)
- Completely Discharged 47.50V

Setting the cut-off higher is better for the batteries.

The batteries recommended for use with the Sunsynk systems are AGM Lead Acid or Lithium Battery Banks. ('AGM' means Absorbed Glass Matt construction that allows the electrolyte to be suspended new the plate's active material. In theory, this enhances both the discharge and recharging efficiency. AGM batteries are very heavy as a result)

State of Charge

Bulk: Bulk charge is the first stage of a battery's charging process where the charger identifies the battery and its needs and then applies a high voltage to do the bulk of the charging. It involves about 80% of the recharge. The properly sized charger will give the battery as much current as it will accept up to charger capacity (25% of battery capacity in Amp hours)

Absorption: To fully charge a battery a period of charging at a relatively high voltage is needed. This period of the charging process is called absorption. This occurs when the charging of a battery has reached reached 80% of its capacity. The remaining charge equals 20% approximately. It makes the charger to hold the voltage at the charger's absorption voltage (between 14.1 VDC and 14.8 VDC, depending on charger set points) and decreasing the current until the battery is fully charged.

Float: The charging voltage is reduced to between 13.0 VDC and 13.8 VDC and held constant, while the current is reduced to less than 1% of battery capacity. This mode can be used to maintain a fully charged battery indefinitely.

Equalisation: This is essentially a controlled overcharge that occurs at the end of the Bulk mode and the absorption phase and is called the 'equalisation voltage'. However, this technically this phase has another function. Higher capacity wet (flooded) batteries sometimes benefit from this procedure, particularly the physically tall batteries. The electrolyte in a wet battery can stratify over time, if not cycled occasionally. In equalisation, the voltage is brought up above typical peak charging voltage well into the gassing stage and maintained for a fixed (but limited) period. This stirs up the chemistry in the entire battery, 'equalising' the strength of the electrolyte, and knocking off any loose sulphating that may be on the battery plates.

5.13. Setting Up a Lithium Battery

To set up a lithium-ion battery, click on the BATTERY icon and visit the 'Batt Type' column.

The screenshot shows a 'Battery Setup (2)' window with a yellow header and a 'Help' button. The window is divided into three tabs: 'Batt type', 'Batt Charge', and 'Shut Down'. Under 'Batt type', there are radio buttons for 'Lithium' (selected), 'AGM V', 'AGM %', and 'No Batt'. Below these is an 'Activate' checkbox. The 'Batt Charge' tab is active, showing input fields for 'Batt Capacity' (0A), 'Charge' (0Ah), and 'Discharge' (0Ah). There are also radio buttons for 'CAN' and 'RS485' (selected), and a 'Protocol' dropdown menu set to '1'. At the bottom are 'Cancel' and 'OK' buttons.

What this page displays:

- This information will only display if the 'Lithium' option is selected under 'Batt Type'.
- The type of communion protocol.
- Approved batteries.

What you can do from this page:

- Set up your lithium battery.

After installing a lithium battery, check on the communications page by clicking on the 'Li BMS' icon to see if the BMS information is visible. If some information is not displayed correctly (it should look like the diagrams below) then there will be a communication error.

Li BMS Help ?	
Sum Data	Details Data
Mean Voltage:50.34V	Charging Voltage :53.2V
Total Current:55.00A	Discharging Voltage :47.0V
Mean Temp :23.5C	Charging current :50A
Total SOC :38%	Discharging current :25A
Dump Energy:57Ah	

Li BMS Help ?								
Sum Data					Details Data			
	Volt	Curr	Temp	SOC	Energy	Charge		Fault
	Volt	Curr				Volt	Curr	
1	50.38V	19.70A	30.8C	52.0%	26.0Ah	0.0V	0.0A	0 0 0
2	50.33V	19.10A	31.0C	51.0%	25.5Ah	53.2V	25.0A	0 0 0
3	50.30V	16.90A	30.2C	12.0%	6.0Ah	53.2V	25.0A	0 0 0
4	0.00V	0.00A	0.0C	0.0%	0.0Ah	0.0V	0.0A	0 0 0
5	0.00V	0.00A	0.0C	0.0%	0.0Ah	0.0V	0.0A	0 0 0
6	0.00V	0.00A	0.0C	0.0%	0.0Ah	0.0V	0.0A	0 0 0
7	0.00V	0.00A	0.0C	0.0%	0.0Ah	0.0V	0.0A	0 0 0
8	0.00V	0.00A	0.0C	0.0%	0.0Ah	0.0V	0.0A	0 0 0
9	0.00V	0.00A	0.0C	0.0%	0.0Ah	0.0V	0.0A	0 0 0
10	0.00V	0.00A	0.0C	0.0%	0.0Ah	0.0V	0.0A	0 0 0
11	0.00V	0.00A	0.0C	0.0%	0.0Ah	0.0V	0.0A	0 0 0
12	0.00V	0.00A	0.0C	0.0%	0.0Ah	0.0V	0.0A	0 0 0
13	0.00V	0.00A	0.0C	0.0%	0.0Ah	0.0V	0.0A	0 0 0
14	0.00V	0.00A	0.0C	0.0%	0.0Ah	0.0V	0.0A	0 0 0
15	0.00V	0.00A	0.0C	0.0%	0.0Ah	0.0V	0.0A	0 0 0

Therefore, if a communication error occurs:

1. Check that your data cable is the correct type.
2. Check that the data cable is plugged into the correct sockets. Usually, RS485 is employed, but some battery manufacturers use others.

NOTICE

With some types of lithium battery, the BMS cannot be controlled by the Sunsynk inverter. In this case, treat the battery as a lead-acid type and set the charging and discharging protocol following the battery manufacturer specification.

It is important to refer to the manuals that manufacturers produce for their batteries. That way, the chance of errors occurring during installation are greatly reduced. Below there is a list of batteries that has been examined, tested, and approved by Sunsynk.

Brand	Model	48V Storage Inverter	RS485 or CAN	Inverter Setup	Notes
Pylon or Equivalent	US2000	✓	CAN	0	
			RS485	5	
	US20000-PLUS	✓	CAN	0	
			RS485	5	
DYNESS	B4850	✓	CAN	0	
	B48100	✓	CAN	0	Short Lione 6&7 at inverter side
	POWERBOX F	✓	CAN	0	
	POWERBOX 9.6	✓	CAN	0	
SolarMD	SS4037	✓	CAN		To be used with V2 Logger
	SS4074	✓	CAN		

	SS202	✓	CAN		http://solar.md.co.za/inverter-compatibility-solar.md/sunsynk-and-solar.md/
Freedomwon	Freedom Lite Commercial 52V and HV Models	✓	CAN		www.freedomwon.co.za/storage/2019/09/freedom-lite-commercial-installation-manual-rev-2-september-2019.pdf
REVOV	1 st and 2 nd life	✓	RS485		PINS 1&2 must be Swopped at Battery side.
SHOTO			No		Voltage Base Charge settings must be used.
HUBBLE			No		Voltage Base Charge settings must be used.
CCGX	48Vxxxx	✓	CAN	0	Need confirm CAN_H CAN_L
SACRED SUN	48Vxxxx	✓	RS485	1	Cut Line 3, 6, 8
SOLAX	48Vxxxx	✓	CAN	0	
KOK	48Vxxxx	✓	RS485	2	
UZ ENERGY	UZ-EB51.2-100-A11	✓	CAN	0	
Topakpower	48Vxxxx	✓	RS485	4	
Hai Ying	HY48050	✓	CAN	0	
Re-Power	LS4850	✓	CAN	0	
Herewin Technology	HY48050	✓	CAN	0	
GenixGreen		✓	RS485	6	
Sunwoda	H4850M	✓	RS485	7	
X-ratong	48Vxxxx	✓	RS485	8	
Enershare Technology	BMS48150	✓	RS485	9	
PYLON 3.0		✓	RS485	12	
Murata		✓	RS485	11	
GS10000		✓	RS485	3	
BPE		✓	CAN	0	
ABOET		✓	CAN	0	
VISION Group		✓	CAN	13	
Alpha		✓	CAN	0	

Backbone	B-LFP51.2V 100Ah and B-LFP51.2V 125Ah	✓	CAN	0	<ul style="list-style-type: none"> • Float voltage 54.5V • Absorption V 55.00V • Disable equalisation 0 Days • Shutdown 20% • Low Batt 35% • Restart 50%
----------	---------------------------------------	---	-----	---	--

NOTICE

When communications between battery and inverter does not exist, do not overcharge your battery bank (current or voltage). Many lithium batteries are limited to 100A, some are lower and some are higher. Ensure that voltage and current specifications provided by the battery manufacturer are followed.

If you are using lead acid batteries then follow the equation of **C x 0.25** which means that the maximum charge or discharge you can apply to a battery is a quarter of the AH rating of the overall battery array. E.g: A 200Ah battery array composed of 4 x 200Ah batteries in series has a maximum discharge of only 50Ah (200 x 0.25 = 50)

Also, ensure the cable is thick enough to support the current and the fuses connected are of the correct rating as per the recommendations of battery manufacturers.

5.14. Program Charge / Discharge Times Page

To set 'Charge' and 'Discharge' times, click on the 'System Mode' icon after clicking on the gear icon.

SYSTEM MODE
Help

Time	Power	SOC/V	Grid	Gen	
<input type="checkbox"/>	<input type="checkbox"/>	<input type="checkbox"/>	<input type="checkbox"/>	<input type="checkbox"/>	<input type="checkbox"/> Zero Export
<input type="checkbox"/>	<input type="checkbox"/>	<input type="checkbox"/>	<input type="checkbox"/>	<input type="checkbox"/>	<input type="checkbox"/> Solar Export
<input type="checkbox"/>	<input type="checkbox"/>	<input type="checkbox"/>	<input type="checkbox"/>	<input type="checkbox"/>	<input type="checkbox"/> Limit to Load Only
<input type="checkbox"/>	<input type="checkbox"/>	<input type="checkbox"/>	<input type="checkbox"/>	<input type="checkbox"/>	<input type="checkbox"/> Zero Export Power
<input type="checkbox"/>	<input type="checkbox"/>	<input type="checkbox"/>	<input type="checkbox"/>	<input type="checkbox"/>	<input type="checkbox"/> Max Sell Power

Use Timer
 Priority Load

Cancel
OK

What this page displays:

- A setting to prevent the inverter exporting power to the grid - 'Zero Export'.
- The ability to limit power supply to only the household loads - 'Solar Export'.
- Set the power limits to supply only the loads connected to the LOAD port - 'Priority to Load Only'.

What you can do from this page:

- Set a real time to charge or discharge the battery.
- Choose to charge the battery from the grid or generator.
- Limit export power to the grid.
- Set the unit to **charge** the battery from the grid or generator ticking 'Grid' or 'Gen' and set what times this needs to occur.
- Set the time to **discharge** the unit to the load or export to the grid by unticking 'Grid' and 'Gen'.

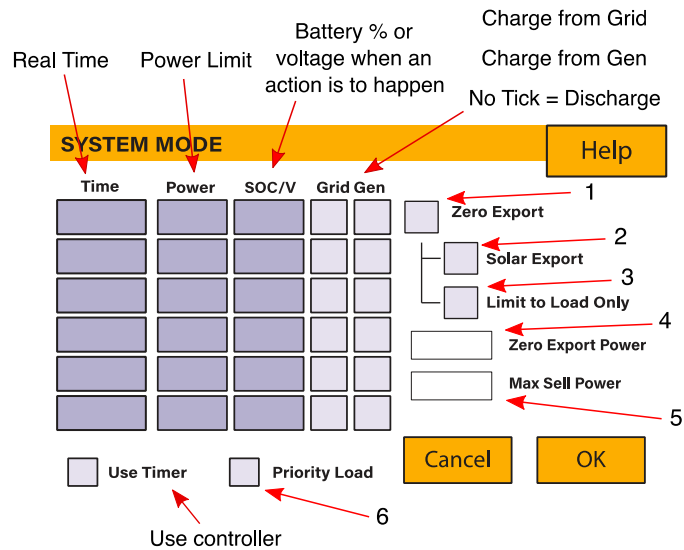

Concerning the detailed figure above:

1. Tick this box to do not export power back to the grid (the CT coil will detect power flowing back to the grid and will reduce the power of the inverter only to supply the local load).
2. Tick this box if you wish to export your solar power back to the grid.
3. Tick this box if you only want to supply power to the load side of the inverter.
4. 'Zero Export Power' is the amount of power flowing from the Grid to the Inverter. Set this value to '20 - 100W' to instruct the inverter to always take the prescribed amount of

power from the Grid to minimise the tripping of sensitive pre-paid electricity meters if 'Reverse Power Detection' occurs.

5. This controls the maximum overall power, both to the 'Load' and 'Grid' ports combined. It is set to Low if an 'over-current' fault occurs

6. Tick this box if you wish to set the solar panels give power to the 'Load'. If you un-tick this box the solar will send power to charge the batteries.

Example:

This example shows the battery being charged up to 100% by both the Grid and Solar PV from 8 a.m. to 11 a.m. and then being able to supply up to 4kW of battery-power to the 'essential' loads from the 'Load' Port until the battery SOC drops to 50%. IMPORTANT - When charging the batteries from the Grid or Generator, please ensure you have set the correct correct battery-charging settings on the battery charge as shown in Section 4.10 'Battery Setup' Home Page. If the 'Use Timer' function is activated then the inverter will use the battery power according to your settings when the Grid is present. If this function is not set, the batteries WILL ONLY be used for backup when there is no utility grid power.

Time	Power	SOC/V	Grid	Gen
08.00.	4000.	100%	<input checked="" type="checkbox"/>	<input type="checkbox"/>
11.00.	5000.	50%	<input type="checkbox"/>	<input type="checkbox"/>
			<input type="checkbox"/>	<input type="checkbox"/>
			<input type="checkbox"/>	<input type="checkbox"/>
			<input type="checkbox"/>	<input type="checkbox"/>
			<input type="checkbox"/>	<input type="checkbox"/>

Zero Export
 Solar Export
 Limit to Load Only
 Zero Export Power
 Max Sell Power
 Use Timer Priority Load

Example:

This is a zero-export power to the grid example.

The power produced is supplying the 'Non-Essential Load' while the inverter is set at a maximum power of 8kW (Max Sell Power). The inverter is connected to the grid, but no export is performed. The unit allows small amounts of power to flow from the Grid (100W Zero Export Power) to prevent any back-flow. In this example, the solar PV is prioritised to supply the Load first and then subsequently, charge the battery.

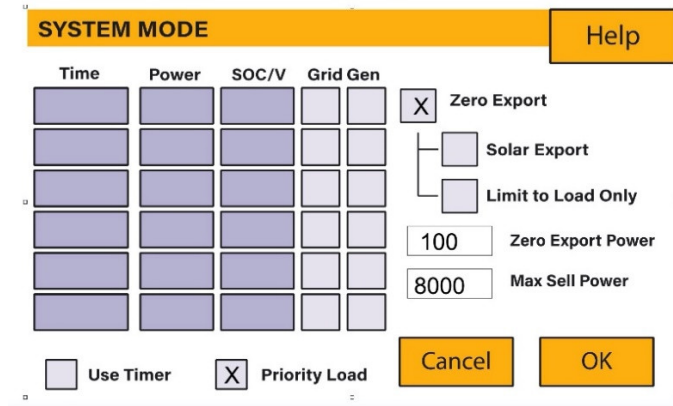

5.15. Grid Supply Voltage and Frequency – Grid Supply Page

On the Settings Menu, click on the GRID icon.

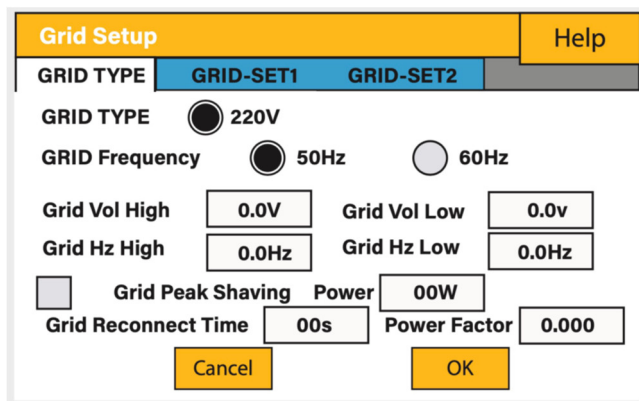

What this page displays:

- Grid frequency setting.
- Grid type (normally 230V three-phase).

What you can do from this page:

- Change grid's frequency setting (normally 50 Hz).
- Set the Maximum Grid Input Voltage ('Grid Vol High').

- Set the Minimum Grid Input Voltage ('Grid Vol Low').
- Set the Maximum Grid Frequency ('Grid Hz High').
- Set the Minimum Grid Frequency ('Grid Hz Low').
- ✓ Select the correct Grid Type in your local area, otherwise the machine will not work or be damaged.
- ✓ Select the correct Grid Frequency in your local area.

Active Power and Reactive Power Setting (Go to GRID-SET2): The inverter is capable of producing reactive power and feeding it into the Grid through this setting. Feed-In management can be controlled directly by the Grid company through a dedicated communication port.

5.15.1. Reactive power setting (QV)

Example: Setting V1=207V and Q1=0.3.

When grid voltage reaches 207V, the inverter will output reactive power at 30% of its rated power.

The screenshot shows the 'Grid Setup' menu with the following settings:

GRID TYPE	GRID-SET1	GRID-SET2
<input type="checkbox"/> L/HVRT		<input type="checkbox"/> L/HFRT
HV2:126.7V	0S	HV2:0.00Hz
HV1:0.0V	0.16S	HV1:0.00Hz
LV1:0.0V	0.16S	LV1:0.00Hz
LV2:0.0V	0.16S	LV2:0.00Hz
LV3:0.0V	0.16S	

Buttons: Cancel, OK

5.15.2. Active power setting (VW):

Example: Setting Vstart: 250V and Vstop=260V.

When the grid voltage reaches 250V and gradually increases to 260V, the inverter output power will gradually decrease. When the voltage reaches to 260V, its output power will decrease to 20% of P start.

DRMs, logic interface for AS/NZS 4777.2: 2015, is used to receive and response commands from grid company and then adjust inverter output power.

The power output or input will vary in response to the AC grid voltage. This function is switched off by default.

1. Click Q (V) for Volt-Var
2. Click VW for Volt-Watt set points, and adjust if needed

The screenshot shows the 'Grid Setup' menu with the following settings:

GRID TYPE	GRID-SET1	GRID-SET2
<input type="checkbox"/> Q(V)		<input type="checkbox"/> FW <input type="checkbox"/> VW
V1:0.0V	Q1: 0.00	Fstart:0.00Hz
V2:0.0V	Q2: 0.00	Fstop:0.00Hz
V3:0.0V	Q3: 0.00	RT:0.0s
V4:0.0V	Q4: 0.00	
Response Time	00s	Normal Ramp Rate
		0.0%/S
		Soft Start Ramp Rate
		0.0%/S

Buttons: Cancel, OK

- Voltage Trip and Ride-Through (L/HVRT)
- Frequency Trip and Ride-Through (L/HFRT)

5.15.3. Volt Variable Mode (Volt-var - VV)

When operating in the Volt-var mode and in line with the Reactive Power Capabilities, the Inverter can provide reactive power output as a function of voltage. The parameters of this function are laid out in the below table with minimum and maximum ranges displayed.

V_{Ref}	Nominal Voltage(V_N) (e.g. 120V)	0.95 of V_N	1.05 of V_N
V_2	$V_{Ref} - 0.03$ of V_N	$V_{Ref} - 0.03$ of V_N	V_{Ref}
Q_2	0	100% of nameplate reactive power capability, absorption ₍₁₎	100% of nameplate reactive power capability, injection ₍₁₎
V_3	$V_{Ref} - 0.03$ of V_N	V_{Ref}	$V_{Ref} + 0.03$ of V_N
Q_3	0	100% of nameplate reactive power capability, absorption	100% of nameplate reactive power capability, injection
V_1	$V_{Ref} - 0.06$ of V_N	0.82 of V_N	$V_2 - 0.02$ of V_N
Q_1	44% of nameplate apparent power	0	100% of nameplate reactive power capability, injection
V_4	$V_{Ref} + 0.06$ V_N	$V_3 + 0.02$ of V_N	1.18 of V
Q_4	44% of nameplate apparent power	100% of nameplate reactive power capability, absorption	0
Response Time	10 Seconds	1 Second	90 Seconds

II.A.2 Volt-var (VV) – UL1741 SA13

When operating in this Volt-var (VV) mode, and consistent with Section II.A (Reactive Power Capabilities), the Inverter shall provide reactive power output as a function of voltage as an illustrative example in Figure 2 and the default values in Table 2.⁴ The Inverter shall have minimum and maximum adjustable ranges per Table 2.

Volt-var Parameters	Default Value	Minimum Adjustable Range	Maximum Adjustable Range
V_{Ref}	Nominal Voltage (V_N) (e.g. 120 volts)	0.95 of V_N	1.05 of V_N
V_2	$V_{Ref} - 0.03$ of V_N	$V_{Ref} - 0.03$ of V_N	V_{Ref}
Q_2	0	100% of nameplate reactive power capability, absorption ⁽¹⁾	100% of nameplate reactive power capability, injection ⁽¹⁾
V_3	$V_{Ref} + 0.03$ of V_N	V_{Ref}	$V_{Ref} + 0.03$ of V_N
Q_3	0	100% of nameplate reactive power capability, absorption ⁽¹⁾	100% of nameplate reactive power capability, injection ⁽¹⁾
V_1	$V_{Ref} - 0.06$ of V_N	0.82 of V_N	$V_2 - 0.02$ of V_N
Q_1	44% of nameplate apparent power	0	100% of nameplate reactive capability, injection ⁽¹⁾
V_4	$V_{Ref} + 0.06$ of V_N	$V_3 + 0.02$ of V_N	1.18 of V_N
Q_4	44% of nameplate apparent power	100% of nameplate reactive capability, absorption ⁽¹⁾	0
Response Time	10 seconds	1 second	90 seconds

Connecting the DRM'S

This can be selected under advance settings.

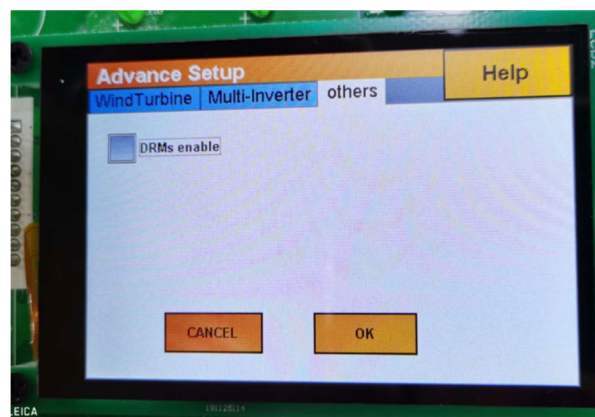

Plug the LAN cable into the socket marked DRMS

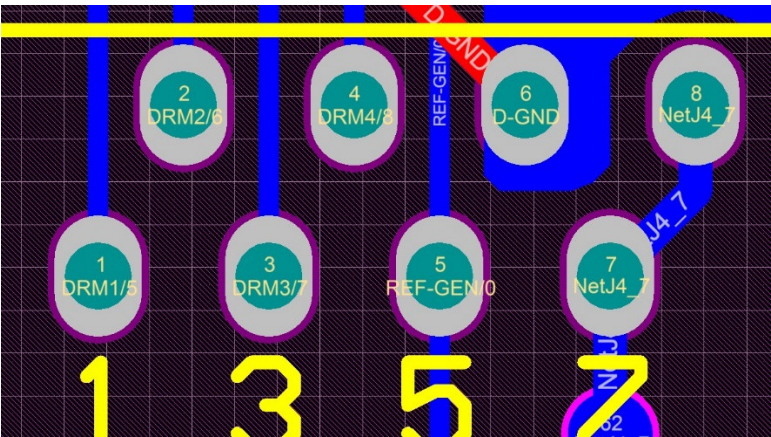
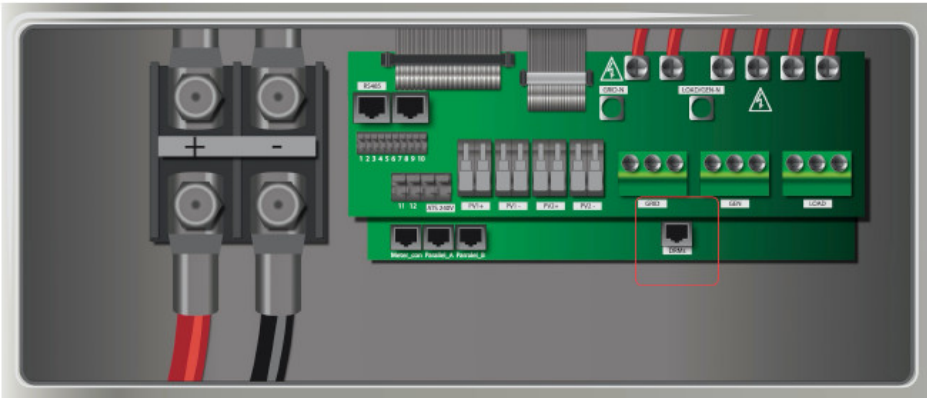

- 1. DRM 1/5
- 2. DRM 2/6
- 3. DRM 3/7
- 4. RDRM 4/8
- 5. Ref 0
- 6. D Ground
- 7. Net J 4-7
- 8. Net J 4-7

5.16. Advanced Settings for Paralleling Inverters

To configure multi-inverter settings, click on the ADVANCE icon.

What this page displays:

- If the inverter operates as a master or a slave.
- Modbus Device ID – ‘Modbus SN’ that must be unique for each inverter connected to the bus/wire.

What you can do from this page:

- Set the inverter as a master or slave per bus/wire.
- Set the phase in which the inverter will be paralleled.
- Set the Modbus SN for paralleling.

The Sunsynk parity inverter can be wired standalone or where more power is required it can be connected in parallel either single or 3 phase configuration. The maximum number of inverters that can be paralleled in a single phase utility grid is three (18kW and 22.8kW for the 6kW and 7.6 kW model, respectively) and the maximum number that can be paralleled in a three-phase utility grid is nine (54kW and 68.4kW for the 6kW and 7.6 kW model, respectively).

To parallel six inverters in a three-phase utility grid is necessary to set three inverters as master and three as slaves:

- Phase A: Master A and Slave A
- Phase B: Master B and Slave B
- Phase C: Master C and Slave C

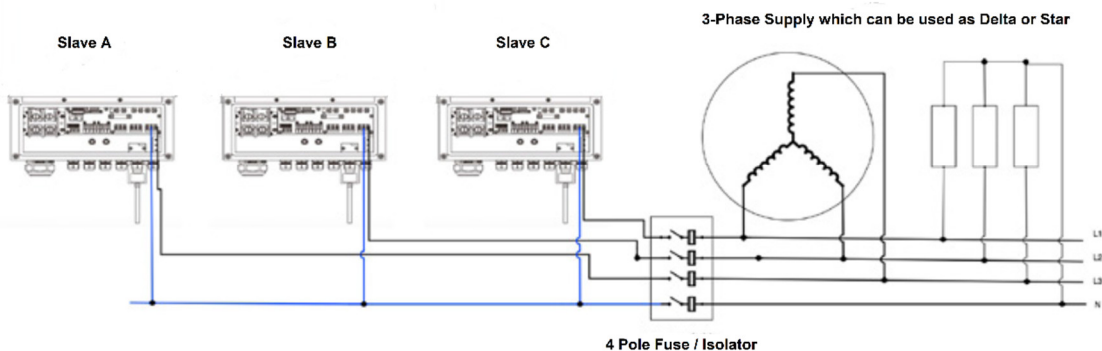

For stability, all the batteries need to be connected in parallel. It is recommended a minimum cable size of 50mm diameter with fuse isolators to each inverter.

Each invert will require a fuse isolator with surge protection and each group circuit will require an RCD. If the batteries as supplying power to the main load during the outage then a change over switch will also be required or a split load can be used.

- The CT coils used to limit export power must only be connected to the master. Therefore, if six inverters are paralleled, three CT coils will be required.
- Connect a RJ45 communication cable between each inverter; the order is not important since both sockets are the same, so there is no IN or OUT.
- Each phase must only have one master and the others set to slave.
- Each inverter must have a unique Modbus number.
- The maximum length of the communication cables is 2 meters (do not exceed this value)
- All batteries must be connected in parallel and the MPPTs must be kept separate.

NOTICE

The cables have two ends, one to be specifically connected to the BMS and the another one to be connected to the inverter, do not change it.

If the communication is not working correctly between inverters then errors will show up on the display. In this case, please check all settings and data cable.

If you need further help please refer to the Sunsynk website where you will find training videos and Frequently Asked Questions www.sunsynk.com. From here you can also update the inverter operating system if required. In most cases, our inverters are fine as they are and no upgrades are needed.

NOTICE

- The load outputs can be connected in parallel.
- The grid input can also be connected in parallel.
- You cannot connect the Aux/Gen port in parallel, because this causes a conflict between the frequency of the generator and the frequency of the grid.

Some common questions that occur when paralleling inverters:

Q1: What is the sequence to install/connect/commission?

First of all, leave the main supplies off. Next, connect all communication cables, set up all LCDs and then, last of all, turn on the main supplies.

Q2: What are the indications that the communication and the system are ok or not?
Parallel errors will be shown as fault F46 on the display.

Q3: What are the consequences of not setting one inverter in a parallel mode?
It can damage the inverter.

Q4: What are the consequences of having more than one Master Inverter or having no inverter set as 'Master'?

It can damage the inverter. There are cases in which it is possible to have more than one master. For example, as aforementioned, six inverters paralleled in a three phase utility grid (three masters).

Q5: What are the consequences for setting A, B, or C phases wrong while in parallel mode?

It can damage the inverter. Recommend checking the phase rotation with a meter before switching on.

Q6: What are the consequences of factory resetting, power cycling, or firmware updating one inverter in a parallel system?

There is no consequence, but the master inverter will keep controlling the slaves.

Q7: What consequences for changing ALL/ANY settings while operating in parallel mode?

It can damage the inverter and fault F46 will be indicated on the display.

5.17. Solar Power Generated

This page shows the daily, monthly, yearly, and total solar power produced. Access this page by clicking on the 'Solar/Turbine' icon on the Home Page.

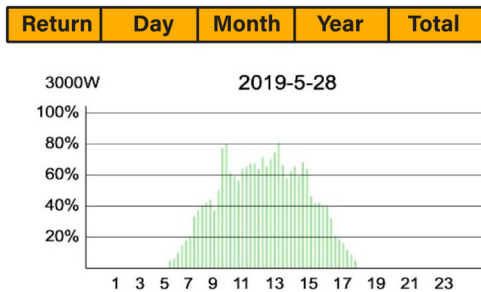

Solar Total Today=0.0KWH Total - 0.0KWH

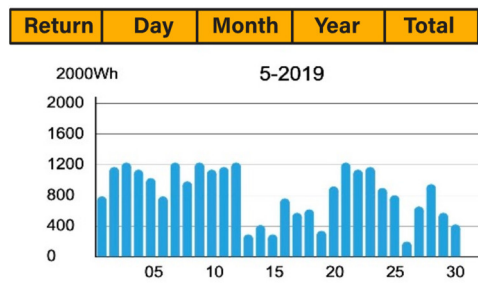

Solar Total Month=0.0KWH Total - 0.0KWH

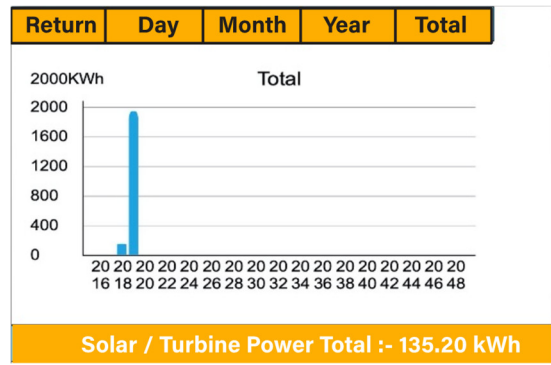
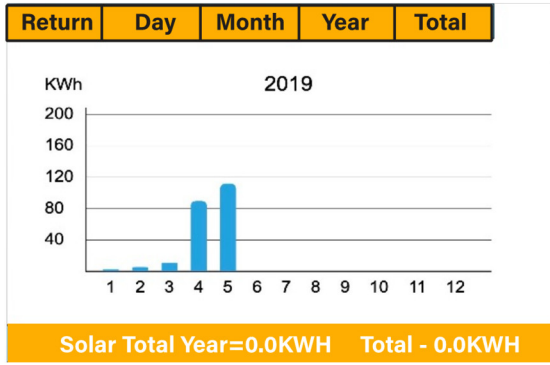

5.18. Grid Power

This page shows the Daily / Monthly / Yearly and total grid power export or consumed. Access this page by clicking on the 'Solar/Turbine' icon on the home page.

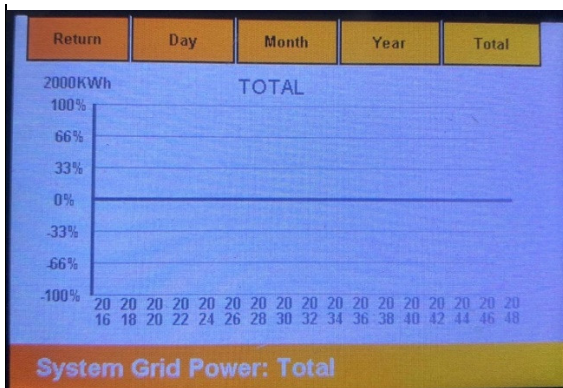
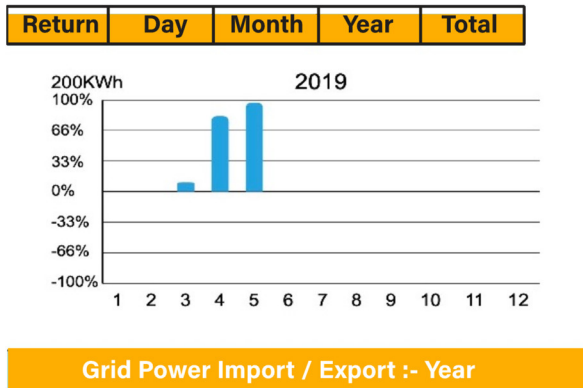
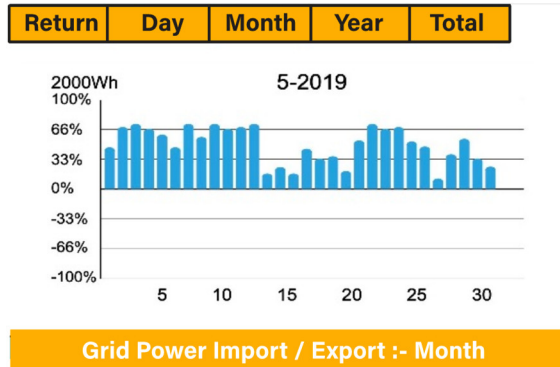
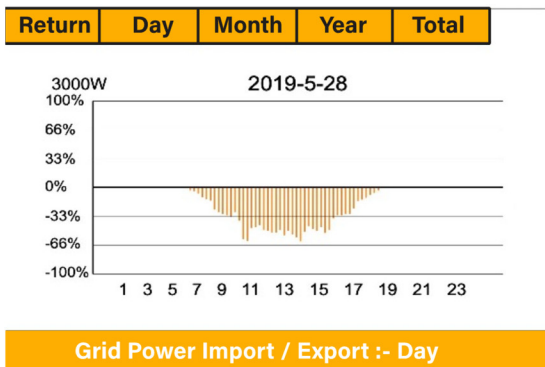

5.19. Advanced Settings for Wind Turbine

To configure wind turbine settings, click on the ADVANCE icon.

What this page displays:

- If one or both of the MPPTs are connected to a wind turbine.

What you can do from this page:

- Select the MPPT to be used as a turbine input.

The table below shows the maximum current depending on the voltage of the wind turbine.

Voltage	Max. Current (Amps)	Power (W)
150	23.33	3500
200	17.50	3500
250	14.00	3500
300	11.67	3500
400	8.75	3500

NOTICE

- DO NOT use a wind turbine that exceeds 400V.
- **Use a self-breaking wind turbine.** Once the batteries are fully charged and the inverter is not exporting any power the load can drop. This can cause the turbine to speed up dramatically, which can be very dangerous and usually happens suddenly. Thus, it is essential to use a self-breaking turbine.

Most wind turbines are three-phase PM type. Therefore, either a wind turbine controller or a direct connection to the MPPT via a simple protection circuit will be required.

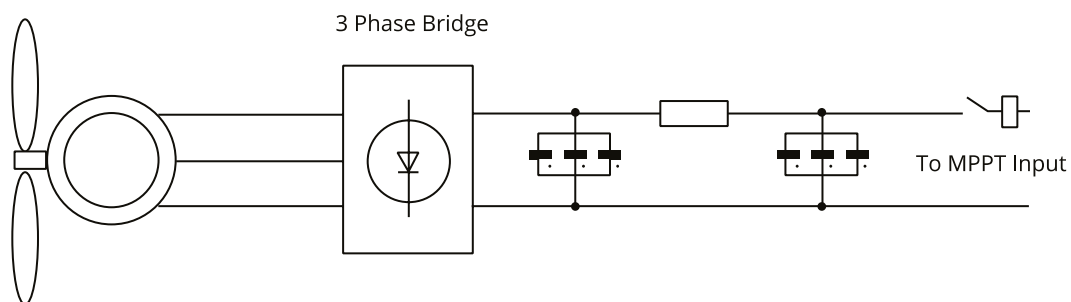

Dump Load or Diversion Load is an important part of an off-grid power system. When the battery (Battery Bank) is fully charged, and the water turbine / wind turbine / solar PV module is still generating, a dump load is a useful device to send spare electricity to. This can be done by using a switch on a smart load option or by utilising a wind turbine controller with a built-in dump load. Also, a hot water tank controlled via a smart-load can act as a good 'dump-load' however, in very windy conditions it may be necessary to shunt the output.

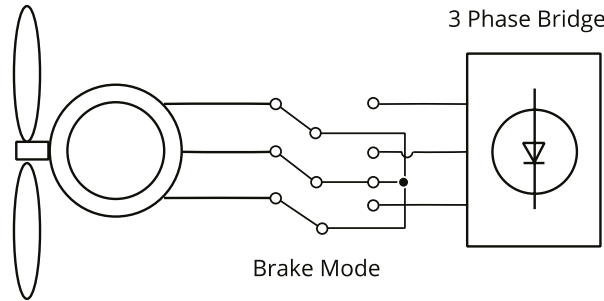

5.20. Advanced Settings for Auxiliary Load

To configure Auxiliary Load (previously known as “smart load”) settings, click on the AUX LOAD icon.

AUX Load
Help

Gen input Gen peak shaving power

Aux load output

For Micro inverter input MI Zero Export

Aux Load OFF Batt

Aux Load ON Batt Solar Power(W)

Cancel
OK

What this page displays:

- Use of the Gen (Aux) input or output.

What you can do from this page:

- Set up a generator input.
- Set up an auxiliary (smart) load.
- Set up Peak Power Shaving.
- Use an additional inverter or micro inverter.

A nice feature of this page is that when the batteries are full and the inverter is still producing power from the solar PV or turbine, it is possible to direct the power generated to another load such as a water heater.

Aux Load off Battery % or Voltage	Battery level when the Aux load switches off
Aux Load on Battery % or Voltage	Battery level when the Aux load switches on.
Solar Power	Power limiter to the maximum power allowed to the Aux load.
Gen Input	Tick this box if using a Generator.
Aux Load Output	Tick this box if using an Aux or Smart Load.

For Micro inverter Input	Tick this box if intending to connect a supplementary inverter or micro inverter (Max. 4kW).
Zero Export	Tick this box to stop exporting power produced by the Aux Load.
Gen Peak Shaving	Tick this box to use peak power shaving.

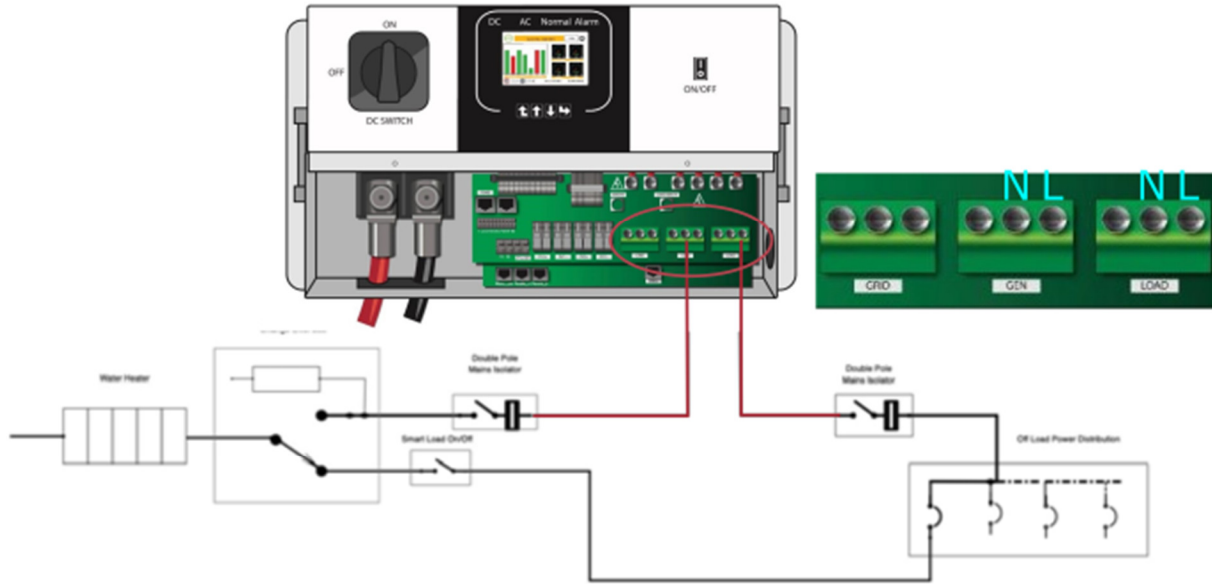

5.21. Advanced Settings for Peak Power Shaving

To configure Peak Power Shaving function, click on the AUX LOAD icon.

AUX Load
Help

Gen input Gen peak shaving power

Aux load output

For Micro inverter input MI Zero Export

Aux Load OFF Batt

Aux Load ON Batt Solar Power(W)

Cancel
OK

What this page displays:

- Generator peak shaving is ON or OFF.
- Peak Power Shaving value.

What you can do from this page:

- Switch on the generator and/or grid peak power saving and set the power shaving value.

Peak Shaving: This is a technique used to reduce electrical power consumption during periods of maximum demand on the utility grid. This enables the user to save substantial amounts of money due to the expensive peak power charges.

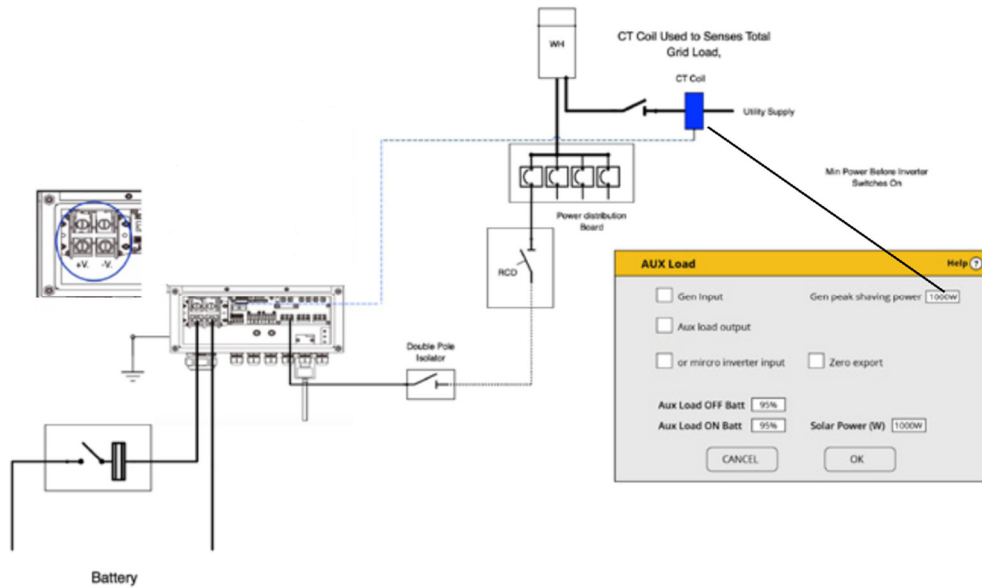

5.22. Fault Codes

To check the fault codes click on the FAULT CODES icon on the settings menu.

Fault Codes		Help ?
Alarms	Occurred	
F56 DC_VoltLow_Fault	2018-10-24 01:07	
F56 DC_VoltLow_Fault	2018-10-24 01:07	
F56 DC_VoltLow_Fault	2018-10-24 01:00	
F56 DC_VoltLow_Fault	2018-10-24 00:55	
F56 DC_VoltLow_Fault	2018-10-24 00:43	
F56 DC_VoltLow_Fault	2018-10-24 00:10	
F56 DC_VoltLow_Fault	2018-10-24 00:08	
F56 DC_VoltLow_Fault	2018-10-24 00:07	

If any of the fault messages listed in the following table appear on your inverter and the fault has not been removed after re-starting, please contact your local vendor or service centre. The following information is required:

1. Inverter serial number.
2. Distributor or service centre of the inverter.
3. On-grid Power Generation Date.
4. The problem description (including the fault code and indicator status displayed on the LCD) with as much detail as possible.
5. Owner's contact information.

Error Code	Description	Solutions
F13	Working Mode Change	Inverter work mode changed 1. Reset the inverter. 2. Seek help from Sunsynk.
F18	AC over current fault or hardware	AC Slide over current fault. 1. Check if the backup load power is within the range of the inverter. 2. Restart, and check if it is normal.
F20	DC over current fault of the hardware	DC Over current fault 1. Check if PV module and battery connections. 2. Reset the system.
F23	AC leakage current is trans over current	Leakage current fault 1. Check the PV module and inverter cables. 2. You may have a faulty PV panel (earth short) 3. Restart inverter
F24	DC insulation impedance failure	PV isolation resistance is too low 1. Check if the connection of PV panels and inverter are firmly connected. 2. Check if the earth bond cable on inverters is connected to the ground.
F26	The bus bar is unbalanced	1. Please wait 5 minutes to see if it returns to normal. 2. Fully reset the inverter.
F35	No at: grid	1. Check if the inverter's connected to the AC grid. 2. Check if the RSCD had not tripped. 3. Check if the switch and fuses between the inverter and grid are all switched on.
F42	AC line low voltage	Grid voltage fault 1. Check if the voltage is in the range of standard voltage in specification this can be adjusted via the grid set up page. 2. Check if grid cables are correctly connected.
F47	AC over frequency	Grid voltage fault

		<ol style="list-style-type: none"> 1. Check if the voltage is in the range of standard voltage in specification this can be adjusted via the grid set up page. 2. Check if grid cables are correctly connected.
F48	AC lower frequency	<p>Grid frequency out of range</p> <ol style="list-style-type: none"> 1. Check if the frequency is in the range of specification 2. You may need to adjust the frequency on the grid set up page.
F56	DC bus bar voltage is too low	<p>Battery low voltage</p> <ol style="list-style-type: none"> 1. Check if the battery voltage is too low. 2. If the battery voltage is too low use the PV or grid to charge the battery. 3. Check the battery BMS Important: Especially with Lithium batteries, ensure that the batteries Max. discharge current or power specification is the same or higher than the inverter specification.
F64	Heat sink high-temperature failure	<p>Heat Sink temp is too high</p> <ol style="list-style-type: none"> 1. Check if the working environment temperature is too high. 2. Turn off the inverter for 30 minutes and restart.

Fault Information	Instruction	Fault Information	Structure
F01	DC_Inversed_Failure	F33	AC_OverCurr_Fault
F02	DC_Insulation_Failure	F34	AC_Overload_Fault
F03	GFDI_Failure	F35	AC_NoUtility_Fault
F04	GFDI_Ground_Failure	F36	AC_GridPhaseSeque_Fault
F05	EEPROM_Read_Failure	F37	AC_Volt_Unbalance_Fault
F06	EEPROM_Write_Failure	F38	AC_Curr_Unbalance_Fault
F07	GFDI_Fuse_Failure	F39	INT_AC_OverCurr_Fault
F08	GFDI_Relay_Failure	F40	INT_DC_OverCurr_Fault
F09	IGBT_Failure	F41	AC_WU_OverVolt_Fault
F10	AuxPowerBoard_Failure	F42	AC_WU_UnderVolt_Fault
F11	AC_MainContactor_Failure	F43	AC_VW_OverVolt_Fault
F12	AC_SlaveContactor_Failure	F44	AC_VW_UnderVolt_Fault
F13	Working_Mode_change	F45	AC_UV_OverVolt_Fault
F14	DC_OverCurr_Failure	F46	AC_UV_UnderVolt_Fault

F15	AC_OverCurr_Failure	F47	AC_OverFreq_Fault
F16	GFCI_Failure	F48	AC_UnderFreq_Fault
F17	Tz_COM_OC_Fault	F49	AC_U_GridCurr_DcHigh_Fault
F18	Tz_Ac_OverCurr_Fault	F50	AC_V_GridCurr_DcHigh_Fault
F19	Tz_Integ_Fault	F51	AC_W_GridCurr_DcHigh_Fault
F20	Tz_Dc_OverCurr_Fault	F52	AC_A_InductCurr_DcHigh_Fault
F21	Tz_GFDI_OC_Fault	F53	AC_B_InductCurr_DcHigh_Fault
F22	Tz_EmergStop_Fault	F54	AC_C_InductCurr_DcHigh_Fault
F23	Tz_GFCI_OC_Fault	F55	DC_VoltHigh_Fault
F24	DC_Insulation_Fault	F56	DC_VoltLow_Fault
F25	DC_Feedback_Fault	F57	AC_BackFeed_Fault
F26	BusUnbalance_Fault	F58	AC_U_GridCurr_High_Fault
F27	DC_Insulation_ISO_Fault	F59	AC_V_GridCurr_High_Fault
F28	DCIOver_M1_Fault	F60	AC_W_GridCurr_High_Fault
F29	AC_AirSwitch_Fault	F61	AC_A_InductCurr_High_Fault
F30	AC_MainContactor_Fault	F62	AC_B_InductCurr_High_Fault
F31	AC_SlaveContactor_Fault	F63	ARC_Fault
F32	DCIOver_M2_Fault	F64	Heatsink_HighTemp_Fault

NOTICE

- The Single-Phase Hybrid Inverter is designed for grid-connected operation.
- The inverters meet the main standards concerning safety and electromagnetic compatibility. Before leaving the factory, all inverters undergo rigorous testing to ensure the inverter can operate reliably as presented in Chapter 3 'Technical Specifications'.

If you need further help please refer to the Sunsynk website where you will find training videos and frequently asked questions www.sunsynk.com.

6. COMMISSIONING

6.1. Startup / Shutdown Procedure

The inverter must be installed by a qualified / licensed electrical engineer in accordance to the countries wiring regulations.

Before switching on, the installation engineer must have completed the Earth Bond, RCD and earth leakage tests, checked that the solar panel Voc voltage does not exceed 480V and checked the battery voltage.

Power on Sequence:

1. Switch on AC
2. Press Start Button
3. Switch on Battery and battery breaker
4. Switch on the DC (PV Isolator)

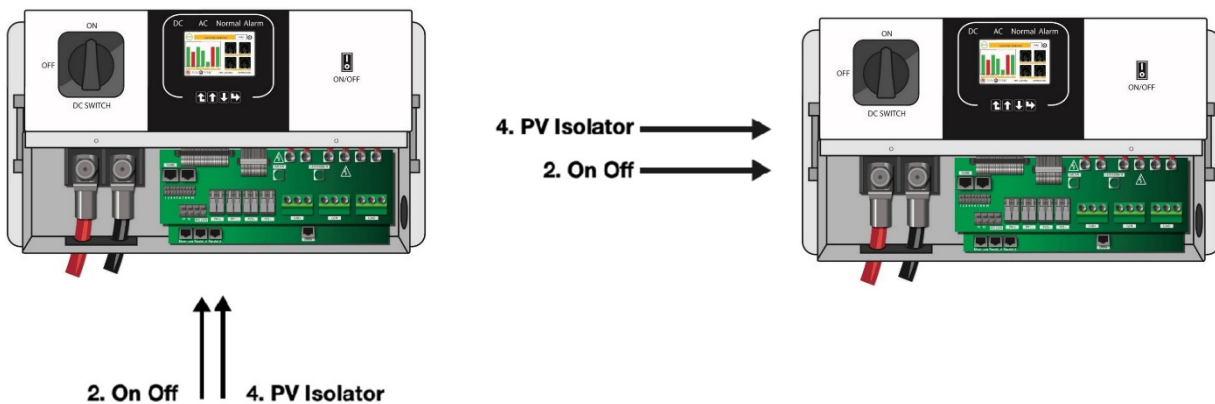







Shutdown Sequence:

- 1) Switch off AC
- 2) Press the start button
- 3) Switch off the battery and the battery breaker
- 4) Switch off the DC (PV isolator)

6.2. Information for Commissioning the Inverter

After you have successfully powered up the inverter, it must be programmed and set up as per the programming feature above.

 <p>Solar</p>	<p>Check each bond on the solar panels</p>	<p>Check the VOC does not exceed 480V</p>	<p>Ensure both MPPTs are balanced</p>
 <p>GRID</p>	<p>Measure the supply voltage check it matches the settings of the inverter</p>	<p>If it falls out of the setting range it will cause the inverter shut down and alarm</p>	<p>See Grid Setup page</p>
 <p>BATTERY</p>	<p>Check the battery charge and discharge is within the C rating of the battery. Too high will damage the battery</p>		<p>Check the battery BMS is communicating with the inverter</p>
 <p>SYSTEM MODE</p>	<p>This is the heart of the system this controller everything</p>	<p>Ensure you are familiar with this, if you fully understand the controller you will fully appreciate the capabilities of there inverter</p>	<p>See section 'Program Charge / Discharge Times'</p>
 <p>ADVANCE</p>	<p>This is for paralleling systems, and wind turbine</p>	<p>If paralleling inverters in 3 Phase check you phase rotation before switching on the AC Load, in 3 Phase the output voltage will increase across phase to 400V</p>	<p>If using a wind turbine please ensure you have the correct limiting resistor, caps and rectifier</p>
 <p>FAULT CODES</p>	<p>Familiarize yourself with common fault codes</p>		

6.3. GDFI Fault

Before the inverter connects to the Grid, it will detect the impedance (effective resistance) of the solar PV + to Ground, and the impedance of the solar PV - to ground. If any of the impedance values are less than 33kΩ, the inverter will not connect to the Grid and will report an error F24 on its LCD.

7. MAINTENANCE

The inverter is low maintenance. However, it is important that at least twice a year (for dusty environments this may need to be carried out weekly) all the cooling fans, air ducts are cleaned and dust free.

Check if there are no fault codes and Lithium battery communication is correct.

Weekly cleaning statement: Suggest micromesh filters as an available option, micro ants here are a real problem.

Appendix A

	Description
CAN	Pin 4: CAN-H Pin 5: CAN-L Pin 1, 3, 6, 7, 8: NC
RS485	Pin 1: RS485B Pin 2: RS485A Pin 3: GND Pin 6: GND Pin 7: RS485B Pin 8: RS485A Pin 4, 5: NC

RS485

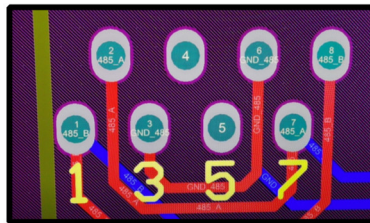

CAN

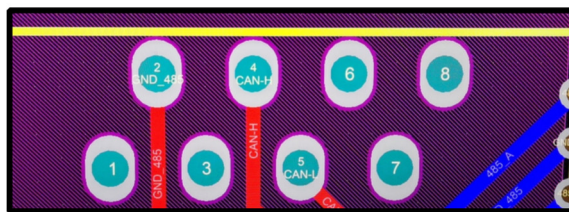

Appendix B

Inverters sold in Australia will be set to the Default Australian standards

Appendix C

The Sunsynk Three-Phase Hybrid Inverter inverter is compatible with the SolarMan app, via a Wifi or GSM data logger (See SolarMan instruction manual).

Appendix D

If an external Residual Current Device (RCD) is used it should be of Type A/AC with a tripping current of 30mA or higher.

Use of RCDs

Residual Current Devices (RCDs): An RCD dedicated for an Inverter Energy System (IES) may be used to meet the mechanical cable protection requirements of AS/NZS3000 for the cable from the switchboard to the IES. If an RCD is installed the engineer must:

1. Disconnect all live conductors (including both active and neutral conductors) and
2. Be of the type specified in the inverter manufacturer's instructions or as labelled on the inverter.

We recommend the use of an RCD on all circuits and sub-circuits connected to the Sunsynk Inverter. Below is the specifications for a Residual Current Breaker with Overcurrent Protection (RCBO)

Earth-leakage protection class	Type A
Earth-leakage sensitivity	30mA
Curve code	C
Network type	AC
Poles description	2P
Earth-leakage protection time delay	Instantaneous

Appendix E

The Sunsynk inverter can be connected to the internet, but you need to add a data logger to do this.

The inverter is compatible with Solar Man data-loggers, which you can obtain from us with your distributor

- 1) LAN-Type Data Logger
- 2) Wi-Fi-Type Data Logger
- 3) GSM-Type Data Logger

To setup the Internet connection for the Data Logger, please refer to the App User instructions. The Data Logger should be connected to the bottom of the inverter via the connection socket marked WIFI.

For more information, training videos, software upgrades, help line, forum please refer to <http://www.sunsynk.com> - Tech Support (Do not forget to register first on the website).



Sunsynk



@energysolutions



@sunsynkofficial

Sunsynk Limited & Global Tech China Ltd,
3 Floor, Wai Yip Industrial Building.

171 Wai Yip Street, Kwun Tong,
Kowloon, Hong Kong.

Tel. HK +852 2884 4318 Fax: +852 2884 4816

Tel. UK +44 151 528 9945

Tel. SA +27 1108 39837

sales@globaltech-china.com

Audio Training manuals on Apple Pod Cast and Spotify

Full training support, manuals and videos on www.sunsynk.com



Global Tech China Ltd

3rd Floor, Wai Yip Street Kwun Tong, Kowloon, Hong Kong

Want to become a distributor? Or want to know more?

Email us: sales@globaltech-china.com Our website: www.sunsynk.com

GT website: www.globaltechchina.com

